

System Installation Guide

iPlanet™ Unified Development Server

Version 5.0

816-1618-01
August 2001

Copyright (c) 2001 Sun Microsystems, Inc., 901 San Antonio Road, Palo Alto, California 94303, U.S.A. All rights reserved.

Sun Microsystems, Inc. has intellectual property rights relating to technology embodied in the product that is described in this document. In particular, and without limitation, these intellectual property rights may include one or more of the U.S. patents listed at <http://www.sun.com/patents> and one or more additional patents or pending patent applications in the U.S. and in other countries.

This document and the product to which it pertains are distributed under licenses restricting their use, copying, distribution, and decompilation. No part of the product or of this document may be reproduced in any form by any means without prior written authorization of Sun and its licensors, if any.

Third-party software, including font technology, is copyrighted and licensed from Sun suppliers.

Sun, Sun Microsystems, the Sun logo, Forte, iPlanet, Unified Development Server, and the iPlanet logo are trademarks or registered trademarks of Sun Microsystems, Inc. in the U.S. and other countries.

UNIX is a registered trademark in the U.S. and other countries, exclusively licensed through X/Open Company, Ltd.

Federal Acquisitions: Commercial Software - Government Users Subject to Standard License Terms and Conditions.

DOCUMENTATION IS PROVIDED "AS IS" AND ALL EXPRESS OR IMPLIED CONDITIONS, REPRESENTATIONS AND WARRANTIES, INCLUDING ANY IMPLIED WARRANTY OF MERCHANTABILITY, FITNESS FOR A PARTICULAR PURPOSE OR NON-INFRINGEMENT, ARE DISCLAIMED, EXCEPT TO THE EXTENT THAT SUCH DISCLAIMERS ARE HELD TO BE LEGALLY INVALID.

Copyright (c) 2001 Sun Microsystems, Inc., 901 San Antonio Road, Palo Alto, California 94303, Etats-Unis. Tous droits réservés.

Sun Microsystems, Inc. a les droits de propriété intellectuels relatants à la technologie incorporée dans le produit qui est décrit dans ce document. En particulier, et sans la limitation, ces droits de propriété intellectuels peuvent inclure un ou plus des brevets américains énumérés à <http://www.sun.com/patents> et un ou les brevets plus supplémentaires ou les applications de brevet en attente dans les Etats - Unis et dans les autres pays.

Ce produit ou document est protégé par un copyright et distribué avec des licences qui en restreignent l'utilisation, la copie, la distribution, et la décompilation. Aucune partie de ce produit ou document ne peut être reproduite sous aucune forme, par quelque moyen que ce soit, sans l'autorisation préalable et écrite de Sun et de ses bailleurs de licence, s'il y en a.

Le logiciel détenu par des tiers, et qui comprend la technologie relative aux polices de caractères, est protégé par un copyright et licencié par des fournisseurs de Sun.

Sun, Sun Microsystems, le logo Sun, Forte, iPlanet, Unified Development Server, et le logo iPlanet sont des marques de fabrique ou des marques déposées de Sun Microsystems, Inc. aux Etats-Unis et dans d'autres pays.

UNIX est une marque déposée aux Etats-Unis et dans d'autres pays et licenciée exclusivement par X/Open Company, Ltd.

LA DOCUMENTATION EST FOURNIE "EN L'ÉTAT" ET TOUTES AUTRES CONDITIONS, DECLARATIONS ET GARANTIES EXPRESSES OU TACITES SONT FORMELLEMENT EXCLUES, DANS LA MESURE AUTORISEE PAR LA LOI APPLICABLE, Y COMPRIS NOTAMMENT TOUTE GARANTIE IMPLICITE RELATIVE A LA QUALITE MARCHANDE, A L'APTITUDE A UNE UTILISATION PARTICULIERE OU A L'ABSENCE DE CONTREFAÇON.

Contents

List of Figures	9
List of Tables	11
List of Procedures	13
List of Code Examples	15
Preface	17
Product Name Change	17
Audience for This Guide	18
Organization of This Guide	18
Text Conventions	19
Other Documentation Resources	19
iPlanet UDS Documentation	20
Express Documentation	20
WebEnterprise and WebEnterprise Designer Documentation	21
Online Help	21
iPlanet UDS Example Programs	21
Viewing and Searching PDF Files	22
Chapter 1 Installation Overview	25
About iPlanet UDS	25
iPlanet UDS Software	26
iPlanet UDS–Runtime Only Software	26
Platform Matrix	28
Setting up an iPlanet UDS Environment	28
iPlanet UDS Nodes	29
Upgrading a Mixed-Node Environment	30
Preparing for Installation	30
Installing iPlanet UDS Software	32

Installation Media	33
iPlanet UDS Platform CD	33
iPlanet UDS–Runtime Only CD	34
Installation Options	35
Installing from a Central Distribution Node	35
Installing from a Local CD-ROM Drive	35
Chapter 2 Installing iPlanet UDS on a UNIX Node	37
Preparing for an iPlanet UDS Installation	38
Platform Matrix	38
User Accounts and Privileges	39
Types of Installations	39
iPlanet UDS Environment	41
Installing the Software	42
Mounting the Distribution CD	43
Installing iPlanet UDS	44
Installing iPlanet UDS–Runtime Only	47
After Installing iPlanet UDS	49
FORTE_ROOT Directory Structure	50
Install Directory	51
Understanding the fortedef Script	52
Creating and Using fortedef Scripts	52
iPlanet UDS Environment Variables	53
Understanding the forteboot Script	54
Creating and Using forteboot Scripts	55
Setting the FORTE_FTLAUNCH_PORT Environment Variable	56
Linking iPlanet UDS with Informix and Sybase	56
Linking iPlanet UDS with Sybase	57
Linking iPlanet UDS with Informix on HP 9000	57
Testing Your Installation	58

Chapter 3 Installing iPlanet UDS on Windows NT and Windows 2000 Nodes	59
Preparing for an iPlanet UDS Installation	60
Platform Matrix	60
User Accounts	61
Administrator Privileges	61
User Account without Administrator Privileges	61
Types of Installations	61
iPlanet UDS Environment	63
Installing the Software	64
Silent Installation	65
Installing iPlanet UDS	66
Full Distributed Installation	67
Custom Installation	71
Installing iPlanet UDS–Runtime Only	77
After Installing iPlanet UDS	82
FORTE_ROOT Directory Structure	84
Install Directory under FORTE_ROOT	85
iPlanet UDS Registry Keys	86
NT Services	88
iPlanet UDS Program Group and Shortcuts	89
Workshops Distributed Shortcut	90
Chapter 4 Installing iPlanet UDS on Windows 98/95 Nodes	93
Preparing for an iPlanet UDS Installation	94
Platform Matrix	94
Types of Installations	95
iPlanet UDS Environment	96
Installing the Software	97
Silent Installation	97
Installing iPlanet UDS	98
Installation Procedures	99
Full Distributed Installation	99
Custom Installation	102
Installing iPlanet UDS–Runtime Only	108
After Installing iPlanet UDS	111
FORTE_ROOT Directory Structure	112
Install Directory under FORTE_ROOT	113
iPlanet UDS Registry Keys	114
iPlanet UDS Program Group and Shortcuts	116
Workshops Distributed Shortcut	117

Chapter 5 Installing iPlanet UDS on an OpenVMS Node	121
Preparing for an iPlanet UDS Installation	122
Platform Matrix	122
Disk Space Requirements	123
Modifying System Parameters	124
Checking Operating System and Software Versions	125
OpenVMS System	125
Motif Runtime Libraries	125
Network Support	125
Compaq C and C++ Compiler and Runtime Libraries	127
Required Target Directory Structure	127
Types of Installations	128
iPlanet UDS Environment	130
Installation Procedures	132
Installing iPlanet UDS	132
Installing iPlanet UDS–Runtime Only	137
After Installing iPlanet UDS	141
FORTE_ROOT Directory Structure	141
FORTE_ROOT:[INSTALL] Directory	143
Editing the System Files	144
Editing the OpenVMS System Startup File	144
Editing the System Login File	145
Shutting Down iPlanet UDS Server Processes	145
iPlanet UDS User Account Requirements	146
iPlanet UDS Server Account Requirements	147
Testing Your Installation	149
Configuration Notes	151
Logical Names	151
Search Priority	152
Network Protocols	152
Setting FORTE_LOCATIONS	152
Setting FORTE_NS_ADDRESS	154

Chapter 6 Installing iPlanet UDS and the iPlanet UDS Transaction Adapter on OS/390	155
Preparing for an iPlanet UDS Installation	155
Platform Matrix	156
Who Should Install the Software?	156
Requirements for Installation	157
Installation Options	157
iPlanet UDS on OS/390 Node	158
iPlanet UDS Environment	159
Installation Procedure	161
After Installing iPlanet UDS	165
FORTE_ROOT Directory Structure	166
Install Directory	167
Understanding the fortedef Script	168
Creating and Using fortedef Scripts	168
iPlanet UDS Environment Variables	169
Understanding the forteboot Script	170
Creating and Using forteboot Scripts	171
Testing iPlanet UDS	172
Customizing Sample Applications for iPlanet UDS Application Server for OS/390	173
Installing the Transaction Adapter for OS/390	174
Requirements	174
Loading the OS/390 Examples	175
Installation Verification Procedures	176
Installation Verification for APPC/MVS	176
Installation Verification for CICS/ESA and CICS/TS	178
Installation Verification for IMS/TM	181

List of Figures

Figure 1-1	iPlanet UDS System Directory Structure	27
Figure 1-2	The iPlanet UDS Platform CD Directories	33
Figure 1-3	The iPlanet UDS–Runtime Only CD Directories	34
Figure 3-1	iPlanet UDS Services as Windows NT Services	88
Figure 3-2	iPlanet UDS Program Group (Windows NT)	89
Figure 3-3	iPlanet UDS Distributed Shortcut (Windows NT)	90
Figure 4-1	iPlanet UDS Program Group (Windows 98)	116
Figure 4-2	iPlanet UDS Distributed Shortcut (Windows NT)	117

List of Tables

Table 1-1	Nodes in an iPlanet UDS Environment	30
Table 1-2	Nodes in an iPlanet UDS–Runtime Only Environment	31
Table 2-1	Nodes in an iPlanet UDS Environment (UNIX)	40
Table 2-2	Nodes in an iPlanet UDS–Runtime Only Environment (UNIX)	40
Table 2-3	Information Required to Install iPlanet UDS (UNIX)	41
Table 2-4	mount Command Summaries for UNIX platforms	43
Table 2-5	Installation Directories for UNIX Platforms	44
Table 2-6	Contents of the FORTE_ROOT directory	50
Table 2-7	FORTE_ROOT/install Directory Contents	51
Table 2-8	iPlanet UDS Environment Variables (UNIX)	53
Table 3-1	Nodes in an iPlanet UDS Environment (Windows NT)	62
Table 3-2	Nodes in an iPlanet UDS–Runtime Only Environment (Windows NT)	62
Table 3-3	Information Required to Install iPlanet UDS (Windows NT)	63
Table 3-4	Windows NT Installation Options	66
Table 3-5	Types of Custom Installations (Windows NT)	71
Table 3-6	Custom Installation Components	72
Table 3-7	Contents of the FORTE_ROOT directory	84
Table 3-8	FORTE_ROOT/install Directory Contents	85
Table 3-9	iPlanet UDS Environment Variables (WIndows NT)	86
Table 3-10	Windows Shortcuts for iPlanet UDS	91
Table 4-1	Nodes in an iPlanet UDS Environment (Windows 98)	95
Table 4-2	Nodes in an iPlanet UDS–Runtime Only Environment (Windows 98)	95
Table 4-3	Information Required to Install iPlanet UDS (Windows 98)	96
Table 4-4	Windows 98 Installation Options	99
Table 4-5	Types of Custom Installations (Windows 98)	102
Table 4-6	Custom Installation Components	103
Table 4-7	Contents of the FORTE_ROOT directory	112

Table 4-8	FORTE_ROOT/install Directory Contents	113
Table 4-9	iPlanet UDS Environment Variables (Windows 98)	115
Table 4-10	Windows Shortcuts for iPlanet UDS	118
Table 5-1	Nodes in an iPlanet UDS Environment (OpenVMS)	128
Table 5-2	Nodes in an iPlanet UDS–Runtime Only Environment (OpenVMS)	129
Table 5-3	Information Required to Install iPlanet UDS (OpenVMS)	130
Table 5-4	Contents of the FORTE_ROOT Directory Structure (OpenVMS)	141
Table 5-5	FORTE_ROOT:[INSTALL] Directory Contents (OpenVMS)	143
Table 5-6	iPlanet UDS Logical Name Tables (OpenVMS)	151
Table 6-1	Information Required to Install iPlanet UDS (OS/390)	159
Table 6-2	Contents of the FORTE_ROOT directory	166
Table 6-3	FORTE_ROOT/install Directory Contents	167
Table 6-4	iPlanet UDS Environment Variables (OS/390)	169

List of Procedures

- To copy the documentation to a client or server 22
- To view and search the documentation 22
- To install iPlanet UDS software in your environment 32
- To install iPlanet UDS software on a UNIX node 44
- To install iPlanet UDS–Runtime Only on a UNIX node 47
- To set the FORTE_FTLAUNCH_PORT environment variable 56
- To execute the linksyb script 57
- To execute the linkix script 57
- To run iPlanet UDS in distributed mode 58
- To run the iPlanet UDS examples from the demo30 repository 58
- To perform a record mode installation 65
- To perform a silent mode installation 65
- To perform a standard, full distributed iPlanet UDS installation 67
- To perform a custom iPlanet UDS installation 73
- To install an iPlanet UDS runtime client 78
- To perform a record mode installation 98
- To perform a silent mode installation 98
- To perform a standard, full distributed iPlanet UDS installation 100
- To perform a custom iPlanet UDS installation 104
- To install an iPlanet UDS runtime client 109
- To check the available disk space on your disks, enter the following commands 123
- To install iPlanet UDS software on an OpenVMS node 133
- To install iPlanet UDS–Runtime Only software on an OpenVMS node 137
- To run iPlanet UDS in distributed mode 149
- To run the iPlanet UDS examples from the demo30 repository 150
- To install iPlanet UDS on an OS/390 node with UNIX Services 161
- To run iPlanet UDS in distributed mode 172

To run the iPlanet UDS examples from the demo30 repository	172
To load the partitioned datasets from the distribution tape	175
To build the side information and TP profiles	177
To execute the APPC/MVS IVP	178
To define the CICS program and corresponding transaction	179
To ensure that the CICS transaction program is installed correctly	180
To execute the CICS IVP transaction through the Transaction Adapter using the iPlanet UDS CICSivp application	181
To ensure that the IMS transaction program is installed correctly	183
To execute the IMS IVP transaction through the Transaction Adapter using the iPlanet UDS IMSivp application	184

List of Code Examples

Verifying the version number of the Compaq C++ compiler	127
Verifying the version number of the Compaq C compiler	127
Verifying the runtime libraries for Compaq C++	127
Verifying the runtime libraries for Compaq C	127
DECnet-only support	153
TCP/IP-only support	153
DECnet and TCP/IP support	153
Syntax for setting FORTE_NS_ADDRESS on DECnet only	154
Syntax for setting FORTE_NS_ADDRESS on TCP/IP only	154
Syntax for setting FORTE_NS_ADDRESS on DECnet and TCP/IP	154

Preface

This *iPlanet UDS System Installation Guide* explains how to install iPlanet UDS software and iPlanet UDS–Runtime Only software on supported platforms.

Chapter 1, “Installation Overview” provides a brief description of the iPlanet UDS system software. Subsequent chapters contain platform-specific installation procedures and additional information about iPlanet UDS system software.

Refer to the platform matrix at <http://www.forte.com/support/platforms.html> for a list of supported platforms and their requirements.

This preface contains the following sections:

- “Product Name Change” on page 17
- “Audience for This Guide” on page 18
- “Organization of This Guide” on page 18
- “Text Conventions” on page 19
- “Other Documentation Resources” on page 19
- “iPlanet UDS Example Programs” on page 21
- “Viewing and Searching PDF Files” on page 22

Product Name Change

Forte 4GL has been renamed the iPlanet Unified Development Server. You will see full references to this name, as well as the abbreviations iPlanet UDS and UDS.

Audience for This Guide

This manual is intended for personnel responsible for installation of iPlanet UDS software.

Organization of This Guide

The following table briefly describes the contents of each chapter:

Chapter	Description
Chapter 1, "Installation Overview"	Provides background information that helps you prepare for installing iPlanet UDS or iPlanet UDS–Runtime Only software.
Chapter 2, "Installing iPlanet UDS on a UNIX Node"	Describes how to install iPlanet UDS software and iPlanet UDS–Runtime Only software on any supported UNIX platform.
Chapter 3, "Installing iPlanet UDS on Windows NT and Windows 2000 Nodes"	Describes how to install iPlanet UDS software and iPlanet UDS–Runtime Only software on Windows NT and Windows 2000 platforms.
Chapter 4, "Installing iPlanet UDS on Windows 98/95 Nodes"	Describes how to install iPlanet UDS software and iPlanet UDS–Runtime Only software on Windows 98 and Windows 95 platforms.
Chapter 5, "Installing iPlanet UDS on an OpenVMS Node"	Describes how to install iPlanet UDS software and iPlanet UDS–Runtime Only software on OpenVMS systems running on Alpha hardware.
Chapter 6, "Installing iPlanet UDS and the iPlanet UDS Transaction Adapter on OS/390"	Describes how to install iPlanet UDS software on an OS/390 node. It also describes how to install the iPlanet UDS DB2 Adapter for OS/390 and the iPlanet UDS Transaction Adapter for OS/390.

Text Conventions

This section provides information about the conventions used in this document.

Format	Description
<i>italics</i>	Italicized text is used to designate a document title, for emphasis, or for a word or phrase being introduced.
monospace	Monospace text represents example code, commands that you enter on the command line, directory, file, or path names, error message text, class names, method names (including all elements in the signature), package names, reserved words, and URLs.
ALL CAPS	Text in all capitals represents environment variables (FORTE_ROOT) or acronyms (UDS, JSP, iMQ). Uppercase text can also represent a constant. Type uppercase text exactly as shown.
Key+Key	Simultaneous keystrokes are joined with a plus sign: Ctrl+A means press both keys simultaneously.
Key-Key	Consecutive keystrokes are joined with a hyphen: Esc-S means press the Esc key, release it, then press the S key.

Other Documentation Resources

In addition to this guide, there are additional documentation resources, which are listed in the following sections. The documentation for all iPlanet UDS products (including Express, WebEnterprise, and WebEnterprise Designer) can be found on the iPlanet UDS Documentation CD. Be sure to read “[Viewing and Searching PDF Files](#)” on page 22 to learn how to view and search the documentation on the iPlanet UDS Documentation CD.

iPlanet UDS documentation can also be found online at <http://docs.iplanet.com/docs/manuals/uds.html>.

The titles of the iPlanet UDS documentation are listed in the following sections.

iPlanet UDS Documentation

- *A Guide to the iPlanet UDS Workshops*
- *Accessing Databases*
- *Building International Applications*
- *Esript and System Agent Reference Guide*
- *Fscript Reference Guide*
- *Getting Started With iPlanet UDS*
- *Integrating with External Systems*
- *iPlanet UDS Java Interoperability Guide*
- *iPlanet UDS Programming Guide*
- *iPlanet UDS System Installation Guide*
- *iPlanet UDS System Management Guide*
- *Programming with System Agents*
- *TOOL Reference Guide*
- *Using iPlanet UDS for OS/390*

Express Documentation

- *A Guide to Express*
- *Customizing Express Applications*
- *Express Installation Guide*

WebEnterprise and WebEnterprise Designer Documentation

- *A Guide to WebEnterprise*
- *Customizing WebEnterprise Designer Applications*
- *Getting Started with WebEnterprise Designer*
- *WebEnterprise Installation Guide*

Online Help

When you are using an iPlanet UDS development application, press the F1 key or use the Help menu to display online help. The help files are also available at the following location in your iPlanet UDS distribution:

```
FORTE_ROOT/userapp/forte/cln/*.hlp.
```

When you are using a script utility, such as Fscript or Escript, type help from the script shell for a description of all commands, or help *<command>* for help on a specific command.

iPlanet UDS Example Programs

A set of example programs is shipped with the iPlanet UDS product. The examples are located in subdirectories under `$FORTE_ROOT/install/examples`. The files containing the examples have a `.pex` suffix. You can search for TOOL commands or anything of special interest with operating system commands. The `.pex` files are text files, so it is safe to edit them, though you should only change private copies of the files.

Viewing and Searching PDF Files

You can view and search iPlanet UDS documentation PDF files directly from the documentation CD-ROM, store them locally on your computer, or store them on a server for multiuser network access.

NOTE You need Acrobat Reader 4.0+ to view and print the files. Acrobat Reader with Search is recommended and is available as a free download from <http://www.adobe.com>. If you do not use Acrobat Reader with Search, you can only view and print files; you cannot search across the collection of files.

➤ **To copy the documentation to a client or server**

1. Copy the `doc` directory and its contents from the CD-ROM to the client or server hard disk.

You can specify any convenient location for the `doc` directory; the location is not dependent on the iPlanet UDS distribution.

2. Set up a directory structure that keeps the `udsdoc.pdf` and the `uds` directory in the same relative location.

The directory structure must be preserved to use the Acrobat search feature.

NOTE To uninstall the documentation, delete the `doc` directory.

➤ **To view and search the documentation**

1. Open the file `udsdoc.pdf`, located in the `doc` directory.
2. Click the Search button at the bottom of the page or select Edit > Search > Query.

3. Enter the word or text string you are looking for in the Find Results Containing Text field of the Adobe Acrobat Search dialog box, and click Search.

A Search Results window displays the documents that contain the desired text. If more than one document from the collection contains the desired text, they are ranked for relevancy.

NOTE For details on how to expand or limit a search query using wild-card characters and operators, see the Adobe Acrobat Help.

4. Click the document title with the highest relevance (usually the first one in the list or with a solid-filled icon) to display the document.

All occurrences of the word or phrase on a page are highlighted.

5. Click the buttons on the Acrobat Reader toolbar or use shortcut keys to navigate through the search results, as shown in the following table:

Toolbar Button	Keyboard Command
Next Highlight	Ctrl+]]
Previous Highlight	Ctrl+[[
Next Document	Ctrl+Shift+]]

To return to the `udsdoc.pdf` file, click the Homepage bookmark at the top of the bookmarks list.

6. To revisit the query results, click the Results button at the bottom of the `udsdoc.pdf` home page or select Edit > Search > Results.

Installation Overview

This chapter, “[Installation Overview](#),” provides background information that helps you prepare for installing iPlanet UDS or iPlanet UDS–Runtime Only software. Before beginning your installation, it is recommended that you read this chapter in its entirety. You should also be familiar with information in the *iPlanet UDS System Management Guide* that describes how to set up and maintain an iPlanet UDS system.

This chapter contains the following sections:

- “[About iPlanet UDS](#)” on page 25
- “[Platform Matrix](#)” on page 28
- “[Setting up an iPlanet UDS Environment](#)” on page 28
- “[Preparing for Installation](#)” on page 30
- “[Installation Media](#)” on page 33

Subsequent chapters provide platform-specific instructions for installing iPlanet UDS and iPlanet UDS–Runtime Only software.

About iPlanet UDS

iPlanet UDS is a software environment for developing, deploying, and managing distributed applications on multiple platforms. It supports the full life cycle of an iPlanet UDS application, from development to the management of the application as it runs on a number of platforms.

An iPlanet UDS environment includes software that operates at a number of different levels, including a runtime environment for iPlanet UDS applications, the development and management of iPlanet UDS applications, and management of an iPlanet UDS system.

iPlanet UDS Software

The distribution on the *iPlanet UDS Platform CD* allows you to install a complete package that lets you develop, deploy, run, and manage applications in an iPlanet UDS environment.

iPlanet UDS–Runtime Only Software

The distribution on the *iPlanet UDS–Runtime Only CD* allows you to install a smaller set of components that let you deploy, run, and manage iPlanet UDS runtime client applications. An iPlanet UDS runtime client can participate in a complete iPlanet UDS environment and can run iPlanet UDS applications. However, you cannot develop iPlanet UDS applications from the software installed from the *iPlanet UDS–Runtime Only CD*.

The following figure illustrates the contents of an iPlanet UDS installation, calling out the differences for an iPlanet UDS–Runtime Only installation. Each platform-specific chapter of this manual contains a description of the contents of the iPlanet UDS directory structure.

Figure 1-1 iPlanet UDS System Directory Structure

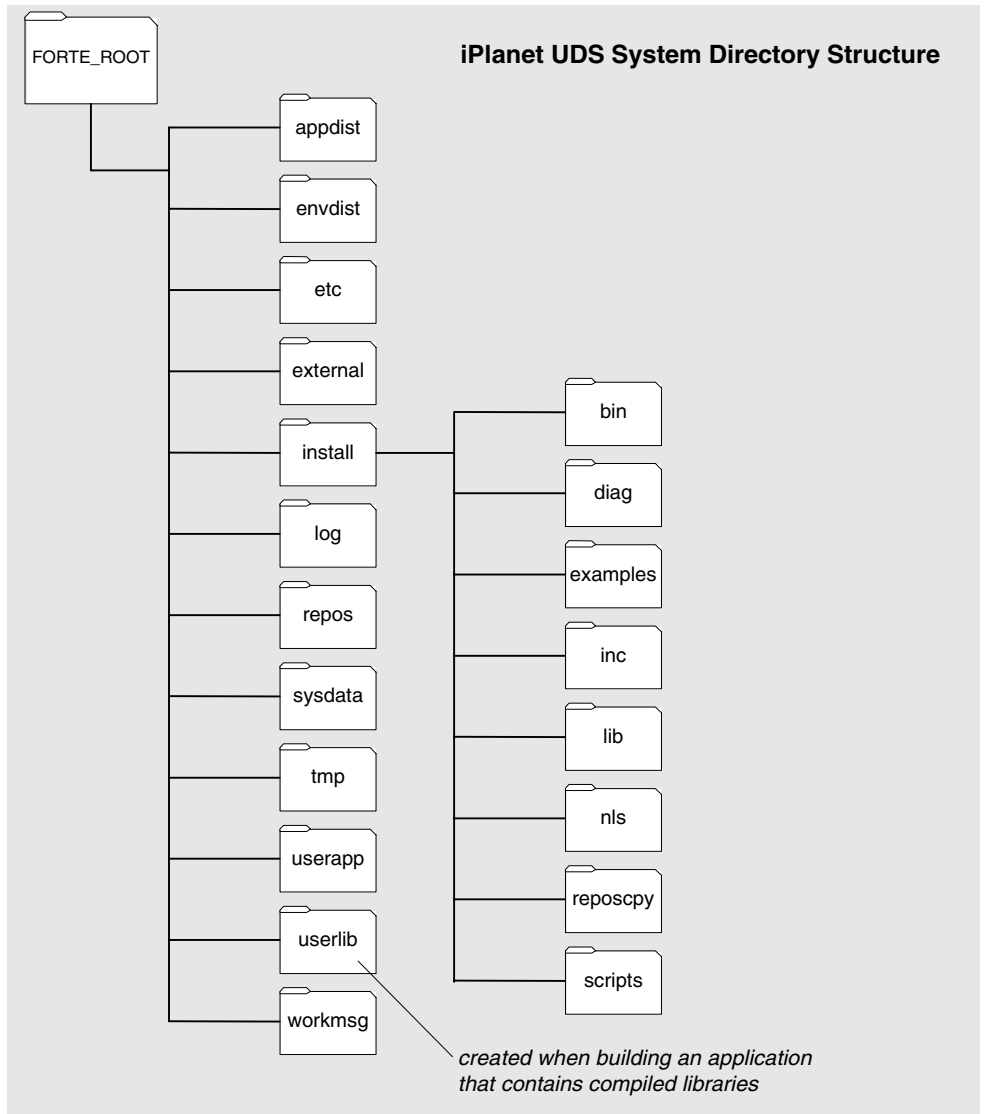

Platform Matrix

The platform matrix, available at <http://www.forte.com/support/platforms.html>, provides detailed information on platforms certified for each iPlanet UDS release. This information includes requirements such as the operating system, database services, and compiler versions supported on each platform as well as which network transport and windowing systems are supported.

NOTE Platform certification and requirements are subject to change for each release of iPlanet UDS. Be sure to consult the platform matrix prior to installation.

Setting up an iPlanet UDS Environment

An iPlanet UDS environment contains the following principal iPlanet UDS system management services, which can be installed on various nodes in your system:

- Environment Manager

Governs the iPlanet UDS environment, supporting iPlanet UDS communication among the nodes in the environment. The Environment Manager process runs on a central server node. An environment can have only one Environment Manager.

- Node Manager

Each node in an iPlanet UDS environment runs a Node Manager process to communicate certain environment-specific information to the Environment Manager.

- Repository service

The repository service, running on a designated server node (often the environment's central server node), governs use of the iPlanet UDS repository, which stores development projects and their components.

iPlanet UDS Nodes

The iPlanet UDS installation program establishes a node's system management processes during installation. You select one of the following options for the target node:

- central server node

Hosts the Environment Manager process (and its iPlanet UDS Name Service), and often the repository server process, as described above. There must be one (and only one) central server node in each iPlanet UDS environment. In any installation, you should first install the central server node—all other node installations rely upon the identity of the central server node.

- server node

Hosts a Node Manager process and can provide certain services to other nodes in the environment. A simple server node can participate fully in developing and distributing iPlanet UDS applications. However, it contains a subset of the software for a central server node. When you install a server node, you are prompted for the iPlanet UDS Name Service address for the Environment Manager on the central server node.

- client node

Participates in an iPlanet UDS environment and can develop iPlanet UDS applications, but cannot run iPlanet UDS server node processes. A client node is intended to run only client partitions of iPlanet UDS applications. A client-only node uses environment services from server nodes. When you install a client node, you are prompted for the iPlanet UDS Name Service address for the Environment Manager on the central server node.

On some platforms, you can choose to install a client node as *standalone* (does not participate in an iPlanet UDS environment).

- iPlanet UDS runtime client node

An iPlanet UDS client node that does not contain any project development components. An iPlanet UDS runtime client node can run iPlanet UDS applications (exclusive of the iPlanet UDS workshops), but cannot develop iPlanet UDS applications. A runtime system node uses less disk storage than a development client node.

Use the *iPlanet UDS–Runtime Only CD* to install an iPlanet UDS runtime client node.

Upgrading a Mixed-Node Environment

In a mixed node environment, where some nodes are running under an iPlanet UDS system prior to release 5.0, repository files for the two systems may be incompatible. For information on upgrading systems and maintaining compatibility with prior releases, refer to the Technote, “Upgrading to iPlanet UDS 5.0 in Mixed-Node Environments,” available from iPlanet technical support.

Preparing for Installation

When installing iPlanet UDS software, you must be prepared to provide the installer with information about your environment. The information you provide may vary, dependent on the type of node you are installing and the platform of the target node.

Table 1-1 and **Table 1-2**, below, list the types of nodes in an iPlanet UDS environment, and the information you need to supply the installation program. Each platform-specific chapter in this manual provides additional information on preparing for an iPlanet UDS installation.

Table 1-1 Nodes in an iPlanet UDS Environment

Node	Node Property and Other Information
Central Server	Installation path Port ID for iPlanet UDS Name Service Environment name Distributed repository name Example applications Database pathnames

Table 1-1 Nodes in an iPlanet UDS Environment (*Continued*)

Node	Node Property and Other Information
Server	Installation path
	Central server node's iPlanet UDS Name Service address
	Database pathnames
	Distributed repository name
	Example applications
Client	Installation path
	Central server node's iPlanet UDS Name Service address
	Distributed repository name
	Example applications

Table 1-2 Nodes in an iPlanet UDS–Runtime Only Environment

Node	Node Property and Other Information
iPlanet UDS Runtime Client	Installation path
	iPlanet UDS Name Service address
	Database pathnames

Installing iPlanet UDS Software

The following procedure outlines the basic steps for installing iPlanet UDS software. Details for installation vary, depending on the target platform. For specific installation instructions, refer to the platform-specific chapters in this manual.

► To install iPlanet UDS software in your environment

1. Verify that all target nodes fulfill requirements outlined in the platform matrix, available from <http://www.forte.com/support/platforms.html>.
2. Verify that your network is running properly and that the installation files are accessible from your network or from a locally mounted CD.
3. Determine the information you need to provide to perform the installation on the target nodes.

Platform-specific chapters in this manual provide information on what you need to provide the installation program.

4. Designate a central server node for the iPlanet UDS environment and install the iPlanet UDS software on that computer.

The iPlanet UDS installation program prompts you for the type of node you are installing.

5. Install iPlanet UDS or iPlanet UDS–Runtime Only software on the remaining nodes that compose your iPlanet UDS environment.
6. Tune the central server node's environment definition to your environment.

On the central server node, the iPlanet UDS installation program builds an environment definition for your environment. As you continue the installation process on other nodes in the environment, each node registers its identity and properties in the environment definition on the central server node. You can modify this definition, as described in the *iPlanet UDS System Management Guide*.

Installation Media

iPlanet UDS and iPlanet UDS–Runtime Only software are provided in CD-ROM format. The CDs conform to the ISO 9660 standard for data, which allows the CDs to be read from a CD-ROM drive on any computer platform.

NOTE iPlanet UDS software for OS/390 is installed from IBM 3490 tape media. For more information on installing iPlanet UDS for OS/390, refer to [Chapter 6, “Installing iPlanet UDS and the iPlanet UDS Transaction Adapter on OS/390.”](#)

iPlanet UDS Platform CD

The *iPlanet UDS Platform CD* includes the iPlanet UDS system software and installer programs for all supported platforms.

NOTE The actual platforms supported and the layout of the CD may vary with each release of iPlanet UDS.

Figure 1-2 The iPlanet UDS Platform CD Directories

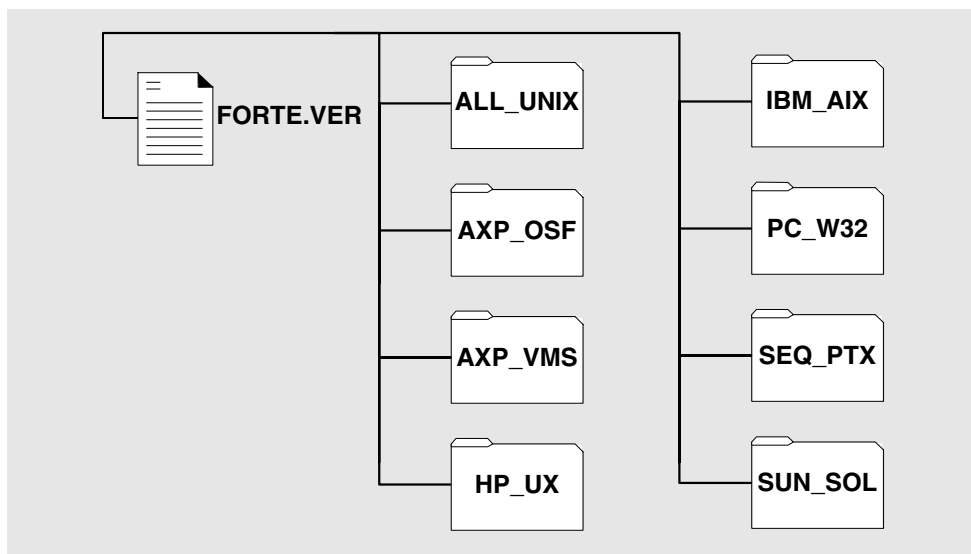

iPlanet UDS–Runtime Only CD

iPlanet UDS–Runtime Only software is provided on a single CD and contains installer programs for all supported platforms.

Figure 1-3 The iPlanet UDS–Runtime Only CD Directories

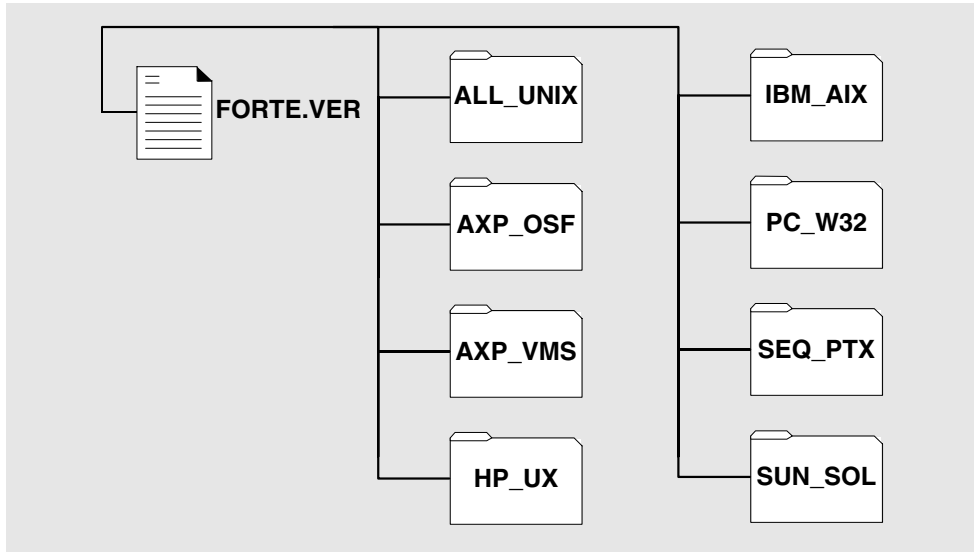

Installation Options

There are two basic approaches to installing iPlanet UDS on any platform. The approach you take depends on how you access the iPlanet UDS installation media. You can install iPlanet UDS onto a target node from either of the following locations:

- a central distribution node
- one of the iPlanet UDS CDs

Installing from a Central Distribution Node

The easiest way to install iPlanet UDS is to designate a server with a CD-ROM drive as a central distribution node. Then mount the appropriate iPlanet UDS CD on the server, making it accessible to your network and any potential installation target nodes. Alternatively, you can copy the necessary files from the CD to a disk on a server that is accessible to the network.

Other nodes in your environment can then access the iPlanet UDS installation software from the central distribution node. Nodes can use either the network operating system to mount the iPlanet UDS CD or a network file copy protocol to download the needed directories from the central distribution node.

If you mount the iPlanet UDS CD from a central distribution node, you can run its installation programs remotely across your network. You can also download the iPlanet UDS directories to a local directory and run the installation program locally.

Installing from a Local CD-ROM Drive

If your target installation node has its own local CD-ROM drive, you can install the iPlanet UDS (or iPlanet UDS–Runtime Only) software directly onto the node from the *iPlanet UDS Platform CD*. You open the appropriate directory on the CD and run the platform-specific installation program for the target node.

Installing iPlanet UDS on a UNIX Node

This chapter describes how to install iPlanet UDS software and iPlanet UDS–Runtime Only software on any supported UNIX platform. This chapter also discusses configuring a UNIX node once you complete installation.

iPlanet UDS software is installed from the *iPlanet UDS Platform CD*. iPlanet UDS–Runtime Only software is installed from the *iPlanet UDS–Runtime Only CD*. For information on iPlanet UDS and iPlanet UDS–Runtime Only software, and on the iPlanet UDS CDs, refer to “[Installation Media](#)” on page 33.

The installation procedure is the same for all supported UNIX platforms, however the system requirements may differ for each platform. Refer to the platform matrix at <http://www.forte.com/support/platforms.html> for the requirements for this release.

The chapter contains the following sections:

- “[Preparing for an iPlanet UDS Installation](#)” on page 38
- “[Installing the Software](#)” on page 42
- “[After Installing iPlanet UDS](#)” on page 49
- “[Testing Your Installation](#)” on page 58

Preparing for an iPlanet UDS Installation

Before beginning an iPlanet UDS installation, you should read **Chapter 1 on page 25**. **Chapter 1** provides background information on iPlanet UDS that is helpful to planning and installing iPlanet UDS and iPlanet UDS–Runtime Only software. You should also be familiar with information in the *iPlanet UDS System Management Guide* that describes how to set up and maintain an iPlanet UDS system.

Platform Matrix

iPlanet UDS has critical dependencies on operating systems, windowing systems, networking systems, runtime libraries, and database management systems. Before installing iPlanet UDS system software, consult the platform matrix (at <http://www.forte.com/support/platforms.html>) to make sure the target platform meets the requirements for this release.

Your system must meet the minimal requirements for the following components:

Component	Comments
Operating system	The version of the UNIX operating systems supported for this release.
Windowing system	For UNIX platforms, the type and version of the windowing system.
Networking system	Nodes with distributed installations must be able to ping server nodes.
C++ compiler	Required if you intend to integrate 3GL programs with iPlanet UDS applications or create compiled partitions and libraries.
Database systems	Required if you plan to access databases through iPlanet UDS. The database environment variable for supported databases must refer to a valid database installation before you install iPlanet UDS. Additionally, the environment variable providing access must be defined according to the database vendor’s instructions. For more information on database access, refer to “Understanding the fortedef Script” on page 52 .
External interface	Required if you plan distributed access using third party tools.

User Accounts and Privileges

The iPlanet UDS installation is not dependent on user status. You can install iPlanet UDS software using any UNIX account and with any privileges. However, your account must have permission to write to the /tmp directory. The installation script establishes UNIX group permissions for using iPlanet UDS based on the login you use when you begin installation.

CAUTION Under all UNIX operating systems (except Compaq Tru64 UNIX), do not log in as root to install iPlanet UDS software. If you log in as root to install iPlanet UDS, the resulting installation is accessible only to the root account.

Compaq Tru64 UNIX If you are installing iPlanet UDS on a Compaq computer under Compaq Tru64 UNIX running C-2 security, *you must install iPlanet UDS using the root account*. If you are not running C-2 security, you should not install iPlanet UDS using the root account.

Types of Installations

“[Setting up an iPlanet UDS Environment](#)” on page 28 discusses the types of nodes in an iPlanet UDS environment. During installation, you select the type of node you are installing and provide information during the installation process.

The following tables list the types of nodes in an iPlanet UDS environment, and the information you need to supply the installation program. “[iPlanet UDS Environment](#)” on page 41 provides descriptions of the information listed in these tables.

For complete information about setting up an iPlanet UDS environment, refer to the *iPlanet UDS System Management Guide*.

Table 2-1 Nodes in an iPlanet UDS Environment (UNIX)

Node	Node Property and Other Information
Central Server	Installation path Port ID for iPlanet UDS Name Service Environment name Distributed repository name Example applications Database pathnames
Server	Installation path Central server node's iPlanet UDS Name Service address Database pathnames Distributed repository name Example applications
Client	Installation path Central server node's iPlanet UDS Name Service address Distributed repository name Example applications

Table 2-2 Nodes in an iPlanet UDS–Runtime Only Environment (UNIX)

Node	Node Property and Other Information
iPlanet UDS Runtime Client	Installation path iPlanet UDS Name Service address Database pathnames

iPlanet UDS Environment

The following table provides details on the information you need to provide during the installation process for iPlanet UDS or iPlanet UDS–Runtime Only. For information on the types of nodes you can install, refer to “Types of Installations” on page 39.

Table 2-3 Information Required to Install iPlanet UDS (UNIX)

Information/Nodes	Description	Default Value
Installation path <i>all nodes</i>	Location of the iPlanet UDS directory structure. This location becomes the value of the FORTE_ROOT environment variable.	/forte
Port ID for iPlanet UDS Name Service <i>central server</i>	<p>A unique port ID on the central server node specifying the Name Service Address. The port ID must be a number between 1025 and 9000 inclusive.</p> <p>The Name Service Address identifies the node in the context of its iPlanet UDS environment, and must therefore be a unique identity within the environment at any time. The address consists of the network name of the central server node and the specified port ID, separated by a colon (for example, <i>myserver:5000</i>). This is the value specified by the node’s FORTE_NS_ADDRESS environment variable, which the installation program sets using the value you provide.</p> <p>When installing the central server node, specify only the port ID.</p>	5000
iPlanet UDS Name Service Address <i>server</i> <i>client only</i> <i>runtime client</i>	<p>The address a server node uses to connect to the name service for the iPlanet UDS environment. The name service is an iPlanet UDS process running on the iPlanet UDS environment’s central server node, governing iPlanet UDS communication among nodes in the environment.</p> <p>The address itself consists of the network name of the central server node and the specified port ID, separated by a colon (for example, <i>myserver:5000</i>). The port ID is specified during the installation of the central server node.</p> <p>The installation program uses the value specified for the iPlanet UDS Name Service Address to set the FORTE_NS_ADDRESS environment variable.</p> <p>You should be able to ping the server by name if the name is part of the name service address, or by the IP address if the IP address is part of the name service address.</p>	none

Table 2-3 Information Required to Install iPlanet UDS (UNIX) (*Continued*)

Information/Nodes	Description	Default Value
Database pathnames <i>central server</i> <i>server</i> <i>runtime client</i>	The pathname for the root of the supported database installation. If Oracle is installed on the node, you must also specify the Oracle server (ORACLE_SID).	<i>Do not specify a path to a database</i>
Environment name <i>central server</i>	A name used in managing the environment. If you plan to connect environments, each environment name should be unique to simplify specification in search paths.	CentralEnv
Distributed repository name <i>central server</i> <i>server</i> <i>client only</i>	The name of the central development repository a node uses in its iPlanet UDS environment for collaborative application development.	CentralRepository
Example applications <i>central server</i> <i>server</i> <i>client only</i>	Several iPlanet UDS example programs that illustrate how to use TOOL and the iPlanet UDS classes. Examples are installed in the \$FORTE_ROOT/install directory and consist of .pex (iPlanet UDS project export) files and other related data files. For more information on the example programs, refer to the manual, <i>A Guide to the iPlanet UDS Workshops</i> .	<i>install examples</i>

Installing the Software

This section describes the installation procedures to install iPlanet UDS and iPlanet UDS–Runtime Only software. The installation script is available from the ALL_UNIX directory of the distribution CD. The script uses the files in the ALL_UNIX directory, together with files in the directory corresponding to your UNIX platform, to assemble an iPlanet UDS installation on your node. (Depending upon your platform, the command and directory names may be in upper or lower case.)

For information on the differences between the iPlanet UDS and iPlanet UDS–Runtime Only, refer to [“About iPlanet UDS” on page 25](#).

Before you begin the installation procedure, you must first mount the distribution CD, as described in the following section. For information on accessing the iPlanet UDS CDs, refer to [“Installation Media” on page 33](#).

Mounting the Distribution CD

Before mounting an iPlanet UDS distribution CD on a UNIX system, an empty directory for mounting the CD must already exist. The following table lists the mount commands for various UNIX platforms. (Consult the platform matrix at <http://www.forte.com/support/platforms.html> for platforms supported for this release).

Table 2-4 mount Command Summaries for UNIX platforms

Platform	Mount command syntax
Solaris	<code>mount -r -F hsfs /dev/dsk/devicename /cdrom</code>
HP/UX	<code>mount -r -t cdfs /dev/dsk/devicename /cdrom</code>
IBM AIX	<code>mount -r -v cdrfs /dev/devicename /cdrom</code>
Compaq Tru64 UNIX, Alpha	<code>mount -r -t cdfs /dev/devicename /cdrom</code> (A cdfs Kernel option entry is required for this command to work.)
Sequent	<code>mount -r -F cdfs /dev/dsk/devicename /cdrom</code>

In the above examples for the mount command:

`-r` specifies that the file system is mounted read only.

`-t arg` (also `-F arg` and `-v arg`, depending on the OS) specifies the type of file system for mounting the CD.

`devicename` is a designated device on your system.

`cdrom` is an existing empty directory representing the mount point for the iPlanet UDS CD.

If you are installing from a server on your network, you need access to the ALL_UNIX directory and to the installation directory corresponding to your UNIX platform.

The following table lists the directories required for each UNIX platform:

Table 2-5 Installation Directories for UNIX Platforms

Platform	Installation Directories
Compaq Tru64 UNIX, Alpha	/ALL_UNIX and /AXP_OSF
Solaris	/ALL_UNIX and /SUN_SOL
HP 9000	/ALL_UNIX and /HP_UX
RS 6000	/ALL_UNIX and /IBM_AIX
Sequent	/ALL_UNIX and /SEQ_PTX

NOTE The actual platforms supported, and the directories available on the iPlanet UDS CDs may vary with each release.

Installing iPlanet UDS

The following procedure describes how to install iPlanet UDS software on a UNIX node. If you are installing iPlanet UDS–Runtime Only software, refer to [“Installing iPlanet UDS–Runtime Only” on page 47](#).

To accept any default values during the installation process, press the Enter or Return key.

► To install iPlanet UDS software on a UNIX node

1. Set your current directory to the source of the installation files.

If you are installing across a network, mount the iPlanet UDS installation directories containing the ALL_UNIX directory and the UNIX directory specific to your platform.

If you are installing from the *iPlanet UDS Platform CD*, mount the CD as explained in [“Mounting the Distribution CD” on page 43](#).

2. Execute the INSTALL.SH program, located in the ALL_UNIX subdirectory of the *iPlanet UDS Platform CD* or in the designated directory of your server node, by typing:

```
./INSTALL.SH
```

3. The installer prompts you for a target directory for your iPlanet UDS installation.

```
Specify the iPlanet UDS installation path (default is /forte):
```

If the target directory you specify does not exist, the installer creates it for you.

4. When installing iPlanet UDS, the installer provides you with the following options:

```

                                iPlanet UDS Installation Menu
                                -----

1 - Install & Setup for Central Server Node
2 - Install & Setup for Server Node
3 - Install & Setup for Client Only
4 - Install Files Only
q - Exit Installation Program

Select Option [1, 2, 3, 4, q (default is 4)]:
```

Refer to [“Types of Installations” on page 39](#) for a description of the installation options.

5. After selecting an installation option, the installer prompts you for additional information.

Refer to [“iPlanet UDS Environment” on page 41](#) for a description of the information you need to provide for each option.

6. Confirm your installation options.

For example:

```
CONFIRMATION:
-----
Installation Option: iPlanet UDS Install & Setup for Central
Server Node.
. . .
Do you wish to continue the installation with these options?
(y/n, default is y)
```

To confirm your selections, and continue with the installation, specify 'y'.

To change a selection, specify 'n' to abort the installation. Then start the installation script again.

After you confirm your choices, the installation proceeds to completion.

NOTE The installation aborts if the target disk is not mounted or if there is not enough free disk space for the installation to complete.

After the installation is complete, proceed to [“After Installing iPlanet UDS” on page 49](#).

Installing iPlanet UDS–Runtime Only

The following procedure describes how to install iPlanet UDS–Runtime Only software on a UNIX node. During the installation process, to accept any default values, press the Enter or Return key.

► To install iPlanet UDS–Runtime Only on a UNIX node

1. Set your current directory to the source of the installation files.

If you are installing across a network, mount the iPlanet UDS installation directories containing the ALL_UNIX directory and the UNIX directory specific to your platform.

If you are installing from the *iPlanet UDS–Runtime Only CD*, mount the CD as explained in the previous section, “[Mounting the Distribution CD](#)” on page 43.

2. Execute the INSTALL.SH program, located in the ALL_UNIX subdirectory of the iPlanet UDS CD or in the designated directory of your server node, by typing:

```
./INSTALL.SH
```

3. The installer prompts you for a target directory for your iPlanet UDS installation.

Specify the iPlanet UDS installation path (default is /forte):

If the target directory you specify does not exist, the installer creates it for you.

4. When installing iPlanet UDS–Runtime Only software, the installer provides you with the following options:

```

iPlanet UDS Runtime Installation
-----

Install & Setup for the iPlanet UDS Runtime System
Q - Exit Installation Program

Press <Enter> to Continue or Q to Exit:

```

5. Press Enter or Return to continue with the installation.

The installer prompts you for additional information. Refer to “[iPlanet UDS Environment](#)” on page 41 for a description of the information you need to provide for each option.

6. Confirm your installation options.

For example:

```
CONFIRMATION:
-----
Installation Option: Install of an iPlanet Runtime System.
. . .
Do you wish to continue the installation with these options?
(y/n, default is y)
```

If you want to change a selection, specify ‘n’ to abort the installation, and then start the installation script again.

After you confirm your choices, the installation proceeds to completion.

NOTE The installation aborts if the target disk is not mounted or if there is not enough free disk space for the installation to complete.

After the installation is complete, proceed to “[After Installing iPlanet UDS](#)” on page 49.

After Installing iPlanet UDS

Your iPlanet UDS installation on UNIX platforms contains the following components:

- FORTE_ROOT directory structure

FORTE_ROOT is the directory you define as the target directory for your iPlanet UDS installation. For information on this directory structure, refer to [“FORTE_ROOT Directory Structure” on page 50](#).

- fortedef script

The fortedef script is a shell script that defines the iPlanet UDS configuration for your node in a series of environment variables. The installation script initially sets these values according to the information you provide.

For more information on the fortedef script, refer to [“Understanding the fortedef Script” on page 52](#).

- forteboot script

The forteboot script is a shell script that you use to start iPlanet UDS. The script contains commands to start iPlanet UDS components according to a configuration you define. Initially, forteboot uses the default configuration defined by the fortedef script.

For more information on the forteboot script, refer to [“Understanding the forteboot Script” on page 54](#).

NOTE The forteboot script is not created for iPlanet UDS–Runtime Only installations.

Before starting iPlanet UDS, you must set the FORTE_FTLAUNCH_PORT environment variable, as described in [“Setting the FORTE_FTLAUNCH_PORT Environment Variable” on page 56](#). Also, you may have to manually provide access to some databases, as described in [“Linking iPlanet UDS with Informix and Sybase” on page 56](#).

FORTE_ROOT Directory Structure

FORTE_ROOT is the directory you define as the target directory for your iPlanet UDS installation. The installation script sets the location of your FORTE_ROOT directory as the value of the FORTE_ROOT environment variable.

NOTE Do not change the structure of the FORTE_ROOT directory. The directory structure must remain intact for iPlanet UDS to function properly—iPlanet UDS relies on the path links within the structure to locate and use iPlanet UDS components.

The installation script installs the FORTE_ROOT structure at the location you choose. You can later move the location of FORTE_ROOT, but you must keep the structure intact. If you move the location of FORTE_ROOT, then you should change any iPlanet UDS environment variable that defines the location of files and directories in the structure.

Table 2-6 describes the contents of the directory structure defined by FORTE_ROOT:

Table 2-6 Contents of the FORTE_ROOT directory

Directory	Content
appdist	Application and library distributions are created here when a developer makes a distribution, or placed here when you copy a distribution from a tape or other media in order to deploy the distribution. Refer to the <i>iPlanet UDS System Management Guide</i> for more information.
envdist	Environment definitions are placed here when they are exported from the environment repository. Refer to the <i>iPlanet UDS System Management Guide</i> for more information.
external	Used as a place to put external libraries. This directory is empty at installation.
install	This directory contains installed iPlanet UDS software, as described in Table 2-7 .
log	System and application log files are written here.
repos	Development repositories are created and stored here. This is the most critical directory to back up.
sysdata	This data contains information important to the iPlanet UDS runtime system and iPlanet UDS system management applications.

Table 2-6 Contents of the FORTE_ROOT directory (*Continued*)

Directory	Content
tmp	This directory is used as a temporary holding directory when making an application or library distribution that contains compiled components.
userapp	Application partitions and libraries are installed here by iPlanet UDS during the deployment process. Only application partitions that run on a particular node are installed in the userapp directory of that node.
userlib	When building an application, this directory is created to hold compiled libraries for the application. This directory does not exist when you first install Forte.
workmsg	This directory is used for working copies of message files for international language support. This directory is empty at installation.

Install Directory

The FORTE_ROOT/install directory contains much of what the iPlanet UDS system uses to run itself, including:

- executable programs
- iPlanet UDS dynamically linked libraries
- B-tree seed repositories
- example programs (if installed)
- scripts
- diagnostic tools

Table 2-7 describes the contents of the FORTE_ROOT/install directory:

Table 2-7 FORTE_ROOT/install Directory Contents

Directory	Content
bin	iPlanet UDS system executables.
diag	Diagnostic tools used by iPlanet UDS technical support.
examples	Sample projects and examples provided by iPlanet UDS.
hyperhlp	(UNIX only) Help files used by iPlanet UDS development and management software.

Table 2-7 FORTE_ROOT/install Directory Contents (*Continued*)

Directory	Content
inc	(Development only) Header and template files used for C++ code generation and 3GL integration.
lib	C and C++ shared libraries used by iPlanet UDS system executables.
nls	Internationalization files.
reposcpy	iPlanet UDS development system seed repository used by the system when creating new repositories and the iPlanet UDS system repository.
scripts	iPlanet UDS scripts, some of which the INSTALL.SH program uses in installing iPlanet UDS on your node, and others which you can use or adapt to automate iPlanet UDS tasks, such as starting and stopping iPlanet UDS and iPlanet UDS components.

Understanding the fortedef Script

The fortedef shell script defines the iPlanet UDS configuration for your node in a series of environment variables, according to the information you pass to it at installation time. It also defines the appropriate shared library path for your UNIX platform.

For a listing of the iPlanet UDS environment variables created during installation, refer to [“iPlanet UDS Environment Variables” on page 53](#). For more information about setting iPlanet UDS environment variables, refer to *A Guide to the iPlanet UDS Workshops*.

The fortedef script comes in two forms, one for the Bourne shell, and one for the C shell:

Bourne Shell: \$FORTE_ROOT/fortedef.sh

C Shell: \$FORTE_ROOT/fortedef.csh

Creating and Using fortedef Scripts

You can use the fortedef script as a template for creating other fortedef scripts for other iPlanet UDS configurations, or for other users. To use your own fortedef scripts, you can either source them manually before starting iPlanet UDS, or reference them in your .login file.

You can also include a fortedef script in your .login file or in your .shrc or .cshrc file. (For HP-UX, use .profile rather than .shrc.)

iPlanet UDS Environment Variables

The following table lists the environment variables created or amended by the iPlanet UDS installer for UNIX installations.

Table 2-8 iPlanet UDS Environment Variables (UNIX)

Environment Variable	Definition	Default Value
FORTE_LOGGER_SETUP	<p>A string defining how iPlanet UDS keeps logs of your use of iPlanet UDS.</p> <p>You can use the iPlanet UDS logging facility to track many kinds of iPlanet UDS processes, and to isolate problems in iPlanet UDS itself and in iPlanet UDS applications that you develop.</p> <p>When you start iPlanet UDS, the runtime system consults this key to determine what logging processes to implement.</p> <p>For more information on how to use iPlanet UDS log files and the iPlanet UDS logging facilities, see the <i>iPlanet UDS System Management Guide</i>.</p>	<code>%stdout (err:sh:*)</code>
FORTE_NS_ADDRESS	<p>The iPlanet UDS name service address for your node. The address of the name service for the iPlanet UDS environment to which you are connecting your node. The name service is an iPlanet UDS process running on the iPlanet UDS environment's central server node, governing iPlanet UDS communication among nodes in the environment.</p> <p>The address itself consists of two parts, separated by a colon, as in <i>myserver:5000</i>, the default value. The first part of the address is the network name of the central server node, and the second part is a number between 1025 and 9000, inclusive.</p>	<code>myserver:5000</code>
FORTE_REPOSNAME	The name of central development repositories.	<code>CentralRepository</code>
FORTE_ROOT	<p>The FORTE_ROOT directory contains your iPlanet UDS installation: the executables and data files that compose the iPlanet UDS system.</p> <p>For more information about the contents of the FORTE_ROOT directory structure, see "FORTE_ROOT Directory Structure" on page 50.</p>	<code>/forte</code>

Table 2-8 iPlanet UDS Environment Variables (UNIX) (*Continued*)

Environment Variable	Definition	Default Value
PATH	Updated to include the path to your iPlanet UDS executables and shared libraries located in subdirectories of the FORTE_ROOT directory.	The path to the file in your FORTE_ROOT directory: FORTE_ROOT/ install/bin
Database Variables	The location of a valid database installation. Actual variables depend upon the database system. An example of the variable for an Oracle database would be ORACLE_HOME= <i>path</i> . For the list of database variables see <i>Accessing Databases</i> .	Determined at installation.
Library Path Variables	Updated to include the path to database libraries. You can modify the library path environment variable to include the library directory for databases you have added after the initial iPlanet UDS installation. The library path environment variable must be set on the server where the database resides before you start the iPlanet UDS Node Manager or iPlanet UDS executable. Library path settings are platform specific. For more information see <i>Accessing Databases</i> .	Automatically set at installation.
For example: LD_LIBRARY_PATH LIBPATH SHLIB_PATH		

Understanding the forteboot Script

The installation script creates the forteboot script that you can use to start iPlanet UDS or any of its components. The script contains commands to start iPlanet UDS server processes.

NOTE The forteboot script is not created for iPlanet UDS–Runtime Only installations.

The forteboot script starts iPlanet UDS system management processes according to the setup options selected during installation. For example, if you selected the central server setup option, the forteboot script starts an environment manager process and repository server process.

The forteboot script comes in two forms, one for the Bourne shell, and one for the C shell:

Bourne Shell: \$FORTE_ROOT/forteboot.sh

C Shell: \$FORTE_ROOT/forteboot.csh

In its default configuration, the script sources the fortedef script to set your iPlanet UDS environment variables before starting iPlanet UDS, and defines command lines for starting iPlanet UDS development applications.

Creating and Using forteboot Scripts

You can modify the forteboot script to add whatever shell-based logic you like, such as prompts for using different fortedef files, or different command lines for starting various iPlanet UDS applications. You can also use the forteboot script as a template to make other forteboot scripts.

You can include the forteboot script in your rc.local file (or, for HPUX, your .brc file in /etc).

You should place the forteboot command at the end of your startup file, after the startup of TCP/IP. Because of the time it takes to start iPlanet UDS server processes, this portion of the startup can take a noticeable length of time.

The following table defines the commands embedded in the forteboot.csh script. The forteboot.sh script contains identical functionality using Bourne shell syntax.

Command	Purpose
source fortedef.csh	Sets variables as defined in fortedef file.
\$FORTE_ROOT/install/bin/start_nodemgr -e <i>environment name</i>	Starts the environment manager process for the environment.
\$FORTE_ROOT/install/bin/rpstart -fr bt: -n <i>repository name</i>	Starts the Repository Service for the environment.

Setting the FORTE_FTLAUNCH_PORT Environment Variable

Before using your iPlanet UDS installation, you must set your FORTE_FTLAUNCH_PORT environment variable. This variable sets the socket at which the iPlanet UDS Launch Server listens to receive commands from the Ftcmd utility. You need a different socket for each instance of the iPlanet UDS Launch Server running on your machine. This means that, on a given machine, each iPlanet UDS user running an instance of the iPlanet UDS Launch Server must use a unique value for the FORTE_FTLAUNCH_PORT environment variable.

You can set the FORTE_FTLAUNCH_PORT variable manually whenever you use iPlanet UDS, as described in the procedure below, or you can set it in your user-specific shell scripts that control your UNIX environment. However, do *not* set this variable in your fortedef file.

► To set the FORTE_FTLAUNCH_PORT environment variable

1. At a UNIX prompt, issue the following command:

```
% setenv FORTE_FTLAUNCH_PORT unique port number
```

You can use any valid port number (from 1025 to 65536, inclusive) for your machine as a port number.

Linking iPlanet UDS with Informix and Sybase

Normally, the installation script links iPlanet UDS executables to the databases of your choice at installation.

Because of the way Sybase and Informix have implemented ports to certain UNIX platforms, in some cases you may need to link iPlanet UDS to one or both of these products manually. You need to manually link Sybase or Informix under the following circumstances:

- On any UNIX platform, if you install Sybase after you install iPlanet UDS
- On the HP 9000 platform, if you install Informix after you install iPlanet UDS

Linking iPlanet UDS with Sybase

Use the iPlanet UDS script, `linksyb`, to manually link iPlanet UDS to a Sybase database.

Before running the `linksyb` script, terminate any iPlanet UDS server partitions you may have running. This includes the iPlanet UDS environment manager, node manager, and repository server.

► To execute the `linksyb` script

1. Change directories to `FORTE_ROOT/install/bin` directory as follows:

```
% cd $FORTE_ROOT/install/bin
```

2. Invoke the script by typing:

```
% ./linksyb
```

NOTE If you are using the HP 9000 platform and need to link iPlanet UDS to both Sybase and Informix, the `linksyb` script can create both links.

Linking iPlanet UDS with Informix on HP 9000

The installation script links Informix libraries into the iPlanet UDS `ftexec` executable. However, on the HP 9000 platform, if you install Informix after you have installed iPlanet UDS, you must perform this linking yourself using the `linkix` utility provided by iPlanet UDS. Some additional disk space is required to support this link.

Before running the `linkix` utility, terminate any iPlanet UDS server partitions you may have running. This includes the iPlanet UDS environment manager, node manager, and repository server.

► To execute the `linkix` script

1. Change directories to `FORTE_ROOT/install/bin` directory as follows:

```
% cd $FORTE_ROOT/install/bin
```

2. Invoke the script:

```
% ./linkix
```

NOTE On the HP 9000 platform, if you need to link iPlanet UDS to both Sybase and Informix, the `linksyb` script (described in [“Linking iPlanet UDS with Sybase”](#)) can create both links.

Testing Your Installation

You can test your installation by running iPlanet UDS in distributed mode.

► To run iPlanet UDS in distributed mode

1. Source the forteboot script to start the central server node processes.

This starts your development environment. For more information on setting up an iPlanet UDS development environment, see the *iPlanet UDS System Management Guide*.

2. Use the forte command to start the iPlanet UDS Repository Workshop.

```
% forte
```

The forte command uses the central development repository you specified during installation.

If you installed the iPlanet UDS example applications, you can run them from the Repository Workshop.

► To run the iPlanet UDS examples from the demo30 repository

1. Issue the following command to start iPlanet UDS in standalone mode, connecting to the demo30 repository.

```
% forte -fs -fr bt:$FORTE_ROOT/repos/demo30
```

For information about iPlanet UDS command syntax and command flags, refer to *A Guide to the iPlanet UDS Workshops*.

Installing iPlanet UDS on Windows NT and Windows 2000 Nodes

This chapter describes how to install iPlanet UDS software and iPlanet UDS–Runtime Only software on Windows NT and Windows 2000 platforms. This chapter also discusses configuring a Windows node once you complete installation.

For information on installing iPlanet UDS on Windows 95/98 for development and deployment of iPlanet UDS applications, refer to [Chapter 4 on page 93](#).

iPlanet UDS software is installed from the *iPlanet UDS Platform CD*. iPlanet UDS–Runtime Only software is installed from the *iPlanet UDS–Runtime Only CD*. For information on iPlanet UDS and iPlanet UDS–Runtime Only software, and on the iPlanet UDS CDs, refer to [“Installation Media” on page 33](#).

The installation procedures are similar for all supported Windows platforms, however the system requirements may differ for each platform. Refer to the platform matrix at <http://www.forte.com/support/platforms.html> for the requirements for this release.

This chapter contains the following sections:

- [“Preparing for an iPlanet UDS Installation” on page 60](#)
- [“Installing the Software” on page 64](#)
- [“After Installing iPlanet UDS” on page 82](#)

Preparing for an iPlanet UDS Installation

Before beginning an iPlanet UDS installation, you should read **Chapter 1 on page 25**. **Chapter 1** provides background information on iPlanet UDS that is helpful to planning and installing iPlanet UDS and iPlanet UDS–Runtime Only software. You should also be familiar with information in the *iPlanet UDS System Management Guide* that describes how to set up and maintain an iPlanet UDS system.

Platform Matrix

iPlanet UDS has critical dependencies on operating systems, windowing systems, networking systems, runtime libraries, and database management systems. Before installing iPlanet UDS system software, consult the platform matrix (at <http://www.forte.com/support/platforms.html>) to make sure the target platform meets the requirements for this release.

Your system must meet the minimal requirements for the following components:

Component	Comments
Operating system	The versions of Microsoft Windows supported.
Windowing system	For Microsoft platforms, this is the native windowing system.
Networking system	Nodes with distributed installations must be able to ping server nodes.
C++ compiler	Required if you intend to integrate 3GL programs with iPlanet UDS applications or create compiled partitions and libraries.
Database systems	Required if you plan to access databases through iPlanet UDS. The database environment variable and/or registry keys for supported databases must refer to a valid database installation before you install iPlanet UDS. Additionally, the environment variables and registry keys providing access must be defined according to the database vendor's instructions.
External interface	Required if you plan distributed access using third party tools.

User Accounts

The setup program establishes access to iPlanet UDS according to the user account you use when you perform the installation. For Windows NT, you can install iPlanet UDS with Administrator privileges, or you can install under a user account without Administrator privileges. For Windows 2000, you must have Administrator privileges to install iPlanet UDS system software.

Administrator Privileges

Installing iPlanet UDS with Windows NT Administrator privileges provides maximum flexibility, allowing you to:

- establish iPlanet UDS environment services as Windows NT services
- configure iPlanet UDS for accessibility by all node users

The setup program automatically enters iPlanet UDS configuration information into the Windows NT registry's HKEY_LOCAL_MACHINE hive, and creates universally accessible shortcuts to iPlanet UDS utilities and components.

User Account without Administrator Privileges

If you install under a user account without Administrator privileges, the setup program configures iPlanet UDS for operation strictly under the user account, entering iPlanet UDS configuration information in the Windows NT registry's HKEY_CURRENT_USER hive, and establishes iPlanet UDS shortcuts visible only to that account. This means that when other users log in to the node under different user accounts, they lack the necessary registry settings and shortcuts to use iPlanet UDS.

Types of Installations

[“Setting up an iPlanet UDS Environment” on page 28](#) discusses the types of nodes in an iPlanet UDS environment. During installation, you select the type of node you are installing and provide information during the installation process.

The following tables list the types of nodes in an iPlanet UDS environment, and the information you need to supply the installation program. [“iPlanet UDS Environment” on page 63](#) provides descriptions of the information listed in these tables.

For complete information about setting up an iPlanet UDS environment, refer to the *iPlanet UDS System Management Guide*.

Table 3-1 Nodes in an iPlanet UDS Environment (Windows NT)

Node	Node Property and Other Information
Central Server	Target directory iPlanet UDS Name Service address Environment name Distributed repository name Example applications
Server	Target directory iPlanet UDS Name Service address Distributed repository name Example applications
Client (Distributed)	Target directory iPlanet UDS Name Service address Distributed repository name Example applications
Client (Standalone)	Target directory Example applications
Install Only	This option copies only the iPlanet UDS directory structure and source files to the target node, leaving the node setup for later.

Table 3-2 Nodes in an iPlanet UDS–Runtime Only Environment (Windows NT)

Node	Node Property and Other Information
iPlanet UDS Runtime Client	Target directory iPlanet UDS Name Service address

iPlanet UDS Environment

During the installation process, the setup program prompts you for information about your iPlanet UDS environment. Using the information you provide, setup creates iPlanet UDS keys in the system registry (also known as iPlanet UDS environment variables). The information you provide the setup program depends on the type of iPlanet UDS node you are installing. The following table describes the information you need to provide the installer.

Table 3-3 Information Required to Install iPlanet UDS (Windows NT)

Information/Nodes	Description	Default Value
Target directory <i>all nodes</i>	The root directory of your iPlanet UDS installation. The setup program creates the FORTE_ROOT environment variable based on this location.	C:\forte
Communications Provider <i>all nodes (except standalone)</i>	The communications interface the Windows client uses to run iPlanet UDS. On Windows NT, iPlanet UDS supports the Windows Sockets interface exclusively, so you do not need to change the default.	Windows Sockets
Name Service Address <i>server client (distributed) runtime client</i>	<p>The address of the name service for the iPlanet UDS environment you are establishing. The name service is an iPlanet UDS process running on the central server node you are installing. The name service governs iPlanet UDS communication among nodes in the environment.</p> <p>The address consists of the network name of the central server node and the specified port ID, separated by a colon (for example, <i>myserver:5000</i>). The port ID must be a number between 1025 and 9000 inclusive.</p> <p>You should be able to ping the server by name if the name is part of the name service address, or by the IP address if the IP address is part of the name service address.</p> <p>The setup program inserts the value you specify into your Windows registry as the value of the FORTE_NS_ADDRESS key in either the HKEY_LOCAL_MACHINE hive (installing with Administrator privileges) or the HKEY_CURRENT_USER hive (installing with User privileges). You can later change this value to connect your node to a different environment by changing the environment variable yourself.</p> <p>For a full description of the changes the setup program makes to your Registry, see “iPlanet UDS Registry Keys” on page 86.</p>	<i>myserver:5000</i>

Table 3-3 Information Required to Install iPlanet UDS (Windows NT) (*Continued*)

Information/Nodes	Description	Default Value
Central repository name <i>central server</i> <i>server</i> <i>client (distributed)</i>	The name of the central development repository the node maintains in its iPlanet UDS environment for collaborative application development.	CentralRepository
Environment name <i>central server</i>	A name used for managing the environment. If you plan to connect environments, each environment name should be unique to simplify specification in search paths.	CentralEnv

Installing the Software

This section describes the installation procedures to install iPlanet UDS and iPlanet UDS–Runtime Only software. The installation setup program is available from the distribution CD.

For information on the differences between the iPlanet UDS and iPlanet UDS–Runtime Only, refer to [“About iPlanet UDS” on page 25](#).

For information on accessing the iPlanet UDS CDs, and the location of the setup program, refer to [“Installation Media” on page 33](#).

NOTE You cannot install onto a remote disk—the target disk must be directly attached to the target node for both client and server installations.

The process for installing iPlanet UDS and iPlanet UDS–Runtime Only software is the same for all supported Windows platforms. Use the setup program to install iPlanet UDS or any of its components, upgrade previous iPlanet UDS installations, or uninstall iPlanet UDS or any of its components.

Silent Installation

The setup program for installing iPlanet UDS on Windows platforms contains a *silent mode* option that allows you to install the software without user interaction. Before you can invoke the silent mode option, you must first perform an interactive install using the *record mode* option. The record mode option creates a `setup.iss` file that contains information for the silent mode option. This file can then be used for subsequent installations.

The following procedures show how to install using the record mode and install mode options. Before performing these procedures, make sure you read the installation instructions contained in this chapter.

► To perform a record mode installation

1. Run the setup program on the *iPlanet UDS* distribution CD with the following options:

```
setup -r [ -f1path\setup.iss ]
```

path specifies the path to a location for the `setup.iss` file. If you do not specify a path to the `setup.iss` file, the file is created in your Winnt directory.

► To perform a silent mode installation

1. If you have not run a record mode installation, run the record mode installation to create a `setup.iss` file.

This file must be created before you can run the installation in silent mode.

2. Run the setup program on the *iPlanet UDS* distribution CD with the following options:

```
setup -s -f1path1\setup.iss [ -f2path2\setup.log ]
```

path1 specifies the path to the location of the `setup.iss` file.

path2 specifies the path to a location for the `setup.log` file.

3. If you created a `setup.log` file, examine it to determine if the installation was successful.

If the installation was successful, `setup.log` contains the following line:

```
ResultCode=0
```

Installing iPlanet UDS

Use the setup program on the *iPlanet UDS Platform CD* to install the iPlanet UDS software. If you are installing iPlanet UDS–Runtime Only software, refer to [“Installing iPlanet UDS–Runtime Only” on page 77](#).

The setup program offers you the installation options listed in [Table 3-4](#).

Table 3-4 Windows NT Installation Options

Option	Description
Full Distributed Installation	<p>Installs iPlanet UDS and configures the target node as the central server node for an iPlanet UDS environment, establishing iPlanet UDS environment variable settings in the Windows NT registry for this purpose.</p> <p>A full distributed installation automatically installs all of the optional components available from a custom installation.</p>
Custom Installation	<p>Allows you to select from the following installation types:</p> <ul style="list-style-type: none"> • central server node • server node • client only (distributed) • client only (stand alone) • install iPlanet UDS files only <p>Also, a custom installation provides options for installing any or all of these iPlanet UDS components:</p> <ul style="list-style-type: none"> • iPlanet UDS Development System (the iPlanet UDS system software) • Examples (iPlanet UDS Example Programs) • iPlanet UDS environment manager and repository server as NT Services • Diagnostic Tools (tools for evaluating problems in your iPlanet UDS environment with help from the iPlanet UDS technical support team.) • Debug Files (files for evaluating problems in your iPlanet UDS environment with help from the iPlanet UDS technical support team.)
Uninstall iPlanet UDS	<p>Uninstalls iPlanet UDS by removing all iPlanet UDS files from specified location.</p>

The following sections provide installation procedures for the following types of iPlanet UDS installations:

- “Full Distributed Installation” below
- “Custom Installation” on page 71

Full Distributed Installation

This section describes how to perform a full distributed iPlanet UDS installation—the iPlanet UDS setup program installs and configures a full iPlanet UDS development system for a central server node in an iPlanet UDS environment.

► To perform a standard, full distributed iPlanet UDS installation

1. From the *iPlanet UDS Platform CD*, start the setup program (available in the PC_W32 folder).

For information on silent mode installations, refer to “Silent Installation” on page 65.

After displaying the splash screen and the license agreement, the setup program displays the Welcome dialog.

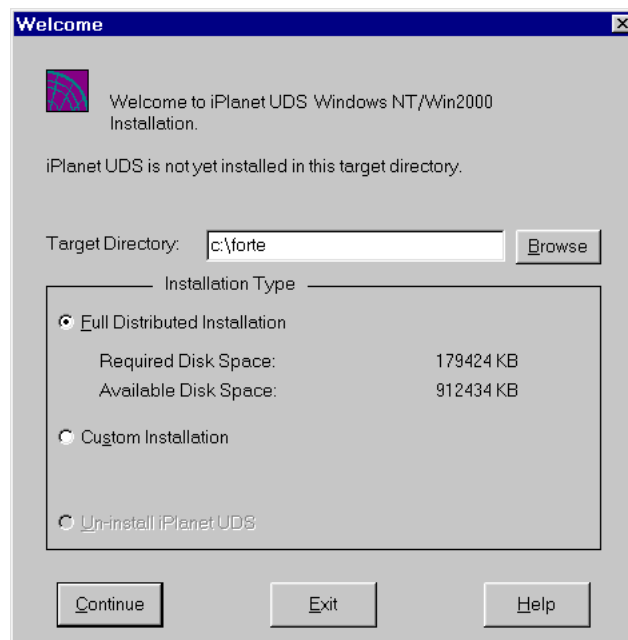

NOTE You can exit the setup program at any time by clicking Exit. However, exiting the installation before its completion may leave changes made by the installer in the Windows registry and iPlanet UDS files on your local disk. Run the setup program's uninstall option to clean up the registry and to remove any installed iPlanet UDS files.

2. Specify a target directory for the iPlanet UDS installation

If the target directory you specify does not exist, the setup program creates it for you. The setup program creates the FORTE_ROOT environment variable based on your specification.

3. Select Full Distributed Installation option and click Continue.

The setup program displays the Distributed Setup dialog, which prompts you for information about your iPlanet UDS environment.

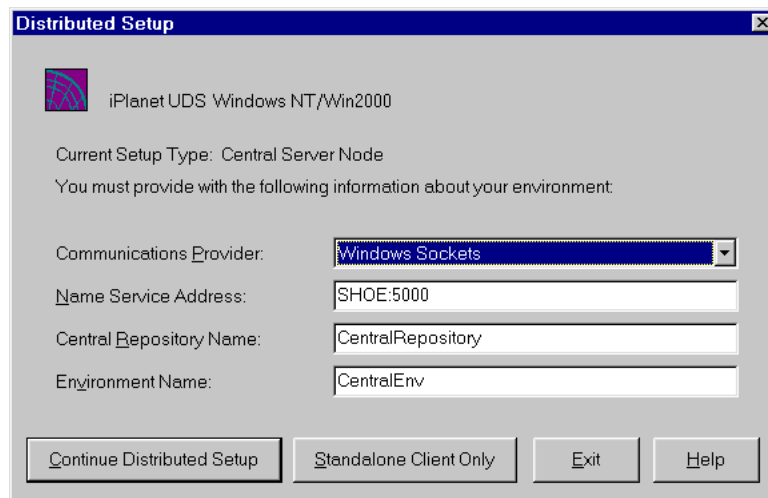
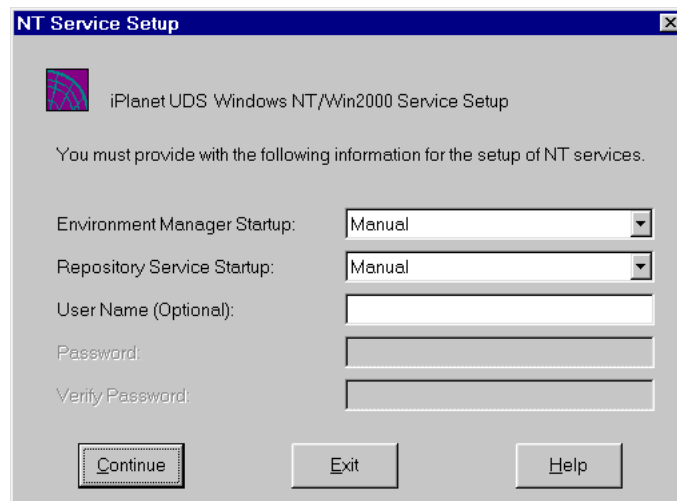

Table 3-3 on page 63 provides a description of the options available to you. If you do not know what values to specify, simply accept the default values. You can change the values later, either by using the iPlanet UDS Control Panel or by editing the Windows registry directly, as described in *A Guide to the iPlanet UDS Workshops*.

- Specify values for the node's iPlanet UDS environment and click Continue Distributed Setup.

If you click Standalone Client Only, the setup program ignores the specifications in the Distributed Setup dialog and instead continues with a standalone client installation.

If you are installing with Administrator privileges, you can configure the Environment Manager and Repository Service as NT services. The setup program displays the NT Service Setup dialog.



- In the NT Service Setup dialog, specify how to set up NT services for the Environment Manager and the Repository Service.

Specify Manual or Automatic. If you specify a User Name, then you must provide a password.

If you do not know what values to specify, simply accept the default values. You can change the values later using the Windows NT Control Panel. For more information on configuring Windows NT services, refer to your Windows NT documentation.

6. The setup program proceeds with the installation.

If you are installing with Administrator privileges, the setup program prompts you for the location for the iPlanet UDS program group. If you specify a *personal program group*, iPlanet UDS is only available to users with Administrator privileges. If you specify a *common program group*, then iPlanet UDS is available to all users.

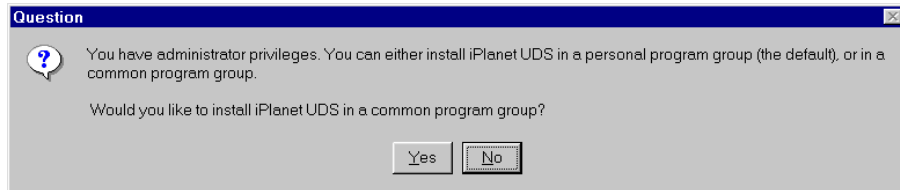

Click No for a personal program group

or

Click Yes for a common program group.

The setup program creates an iPlanet UDS program group and installs shortcuts in the Windows Start menu for starting and administering iPlanet UDS.

When the distributed setup installation is complete, the setup program displays the Installation Complete dialog.

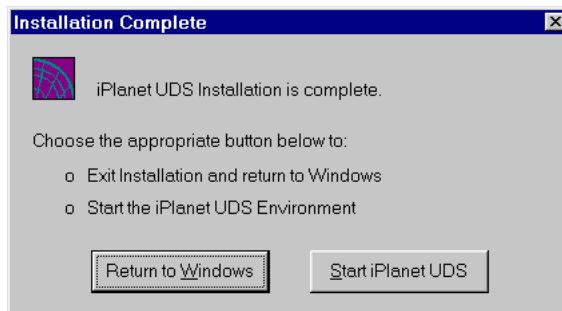

7. Click Return to Windows or Start Forte to exit the setup program.

If you start iPlanet UDS, iPlanet UDS connects to the examples repository created during installation.

Proceed to [“After Installing iPlanet UDS” on page 82](#) for more information on your iPlanet UDS installation.

Custom Installation

This section describes how to perform a custom installation of iPlanet UDS software. Use a custom installation to install a simple server or a client node. The custom installation option also provides more flexibility when installing a central server node.

Table 3-5, below, summarizes the types of installations available when you choose the custom installation option. For more information on each type, refer to “**Types of Installations**” on page 61.

Table 3-5 Types of Custom Installations (Windows NT)

Setup Type	Description
Central Server Node	Specifies that the target node supports iPlanet UDS server partitions and hosts the iPlanet UDS system management processes—the Environment Manager and Repository Server—for the iPlanet UDS environment. For a central server node, you can configure the iPlanet UDS system management services as Windows NT services. To do this, you must log in as a user with Administrator privileges to perform the installation.
Server Node	Specifies that the target node support iPlanet UDS server partitions, but is not a central server node. A repository server is not automatically installed.
Client Only (Distributed)	<p>Installs iPlanet UDS, and configures the node for participation in a iPlanet UDS environment, establishing appropriate iPlanet UDS settings in the Windows registry.</p> <p>This option differs from the default Full Distributed Installation only in allowing you to exclude the iPlanet UDS examples and iPlanet UDS diagnostic tools from the installation.</p>
Client Only (Standalone)	<p>Installs iPlanet UDS and prepares the node to run without connection to an iPlanet UDS environment. Unlike the Client Only (Distributed) option, this option does not add iPlanet UDS networking information to the Windows registry, nor does it create a shortcut in the Start menu for the iPlanet UDS node manager.</p> <p>(For information on the changes the setup program makes to the Windows registry, refer to “iPlanet UDS Registry Keys” on page 86.)</p>
Install Only	Installs only the iPlanet UDS files on your system, leaving you to configure iPlanet UDS on your own. This option does not create shortcuts for using iPlanet UDS, nor does it make any changes to the Windows registry.

In a custom installation, you can specify the following components to install. Not all components are available for all installation options.

Table 3-6 Custom Installation Components

Option	Description
iPlanet UDS Development System	The files necessary to run the iPlanet UDS development system. (This option cannot be disabled.)
Examples	<p>Several iPlanet UDS example programs that illustrate how to use TOOL and the iPlanet UDS classes. Examples are installed in the %FORTE_ROOT%\install directory and consist of .pex (iPlanet UDS project export) files and other related data files. Additionally, the examples are imported into a special repository, demo30, in the %FORTE_ROOT%\repos directory.</p> <p>For more information on the example programs, refer to the manual, <i>A Guide to the iPlanet UDS Workshops</i>.</p>
Diagnostic Tools	Tools for evaluating problems (with help from the iPlanet UDS technical support team) in your iPlanet UDS environment.
NT Services	Configures your node to run the iPlanet UDS environment manager and repository service as Windows NT services; the installation process gives you configuration options for the services during installation. This option is only available to server nodes with Windows NT Administrator privileges.
Debug files	Debugging files, each one a companion to an iPlanet UDS executable or dynamically linked library. These files are debugging tools for use by iPlanet UDS engineers in evaluating system problems; they are not necessary for using iPlanet UDS software. You can install them at any time by restarting the setup program.

NOTE You can bypass automatic configuration of your iPlanet UDS environment during setup, and instead accept the default values. After completing the installation, you can specify the iPlanet UDS environment settings from the iPlanet UDS Control Panel or by editing the Windows registry.

► **To perform a custom iPlanet UDS installation**

1. Start the setup program.

For information on silent mode installations, refer to “[Silent Installation](#)” on [page 65](#).

After displaying the splash screen and license information, the setup program displays the Welcome dialog.

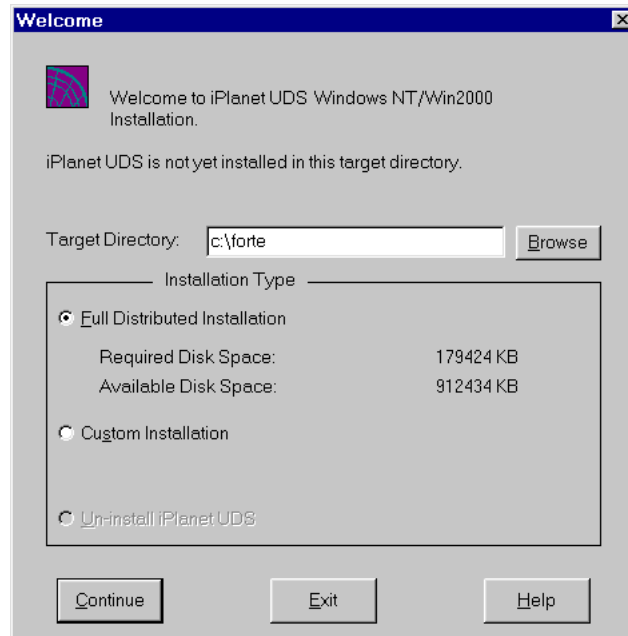

NOTE You can exit the setup program at any time by clicking Exit. However, exiting the installation before its completion may leave changes made by the installer in the Windows registry and iPlanet UDS files on your local disk. Run the setup program’s uninstall option to clean up the registry and to remove any installed iPlanet UDS files.

2. Specify a target directory for the iPlanet UDS installation

If the target directory you specify does not exist, the setup program creates it for you. The setup program creates the FORTE_ROOT environment variable based on your specification.

3. Select the Custom Installation option, then click Continue.

The setup program displays the Custom Installation dialog, which prompts you for the type of installation you are performing and for additional components to install.

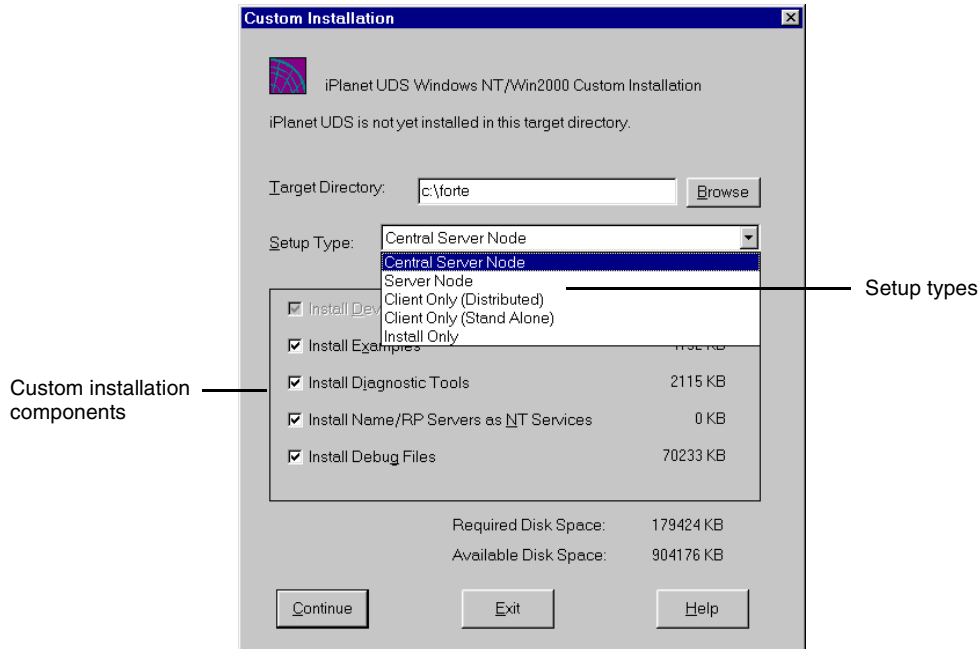

Table 3-5 on page 71 summarizes the types of installations you can perform. For additional information on each setup type, refer to “Types of Installations” on page 61.

Table 3-6 on page 72 describes the custom installation components.

4. Select the setup type and custom installation components to install, and then click Continue.

If you selected the Client Only (Standalone) option or the Install Files Only option, there are no additional specifications—the setup program begins the installation. Proceed to [Step 7 on page 76](#).

If you selected a central server node, server node, or client (distributed) node the installer displays the Distributed Setup dialog.

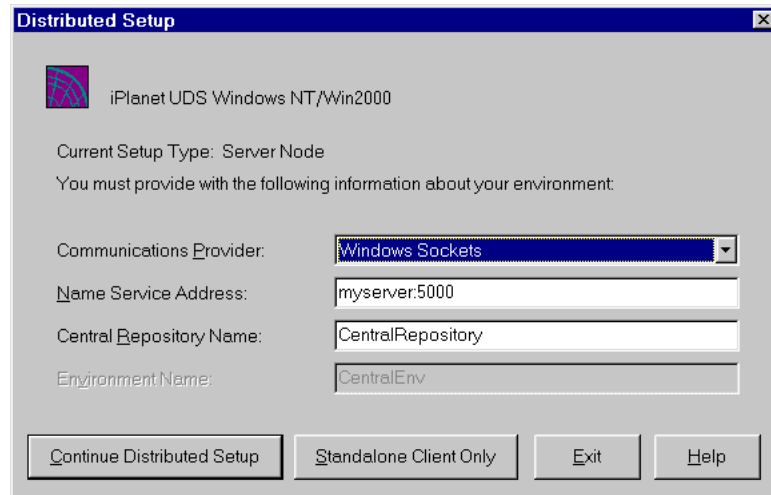

Table 3-3 on page 63 describes the Distributed Setup options.

5. In the Distributed Setup dialog, enter the appropriate values for the target node and then click either Continue Distributed Setup or Standalone Client Only.

If you click Standalone Client Only, the setup program ignores the specifications in the Distributed Setup dialog and instead continues with a standalone client installation.

If you do not know what to specify for a distributed setup, proceed with the default values. After installation is complete, you can add the correct values either by using the iPlanet UDS Control Panel or by editing the Windows registry.

If you are installing with Administrator privileges, you can configure the Environment Manager and Repository Service as NT services. The setup program displays the NT Service Setup dialog.

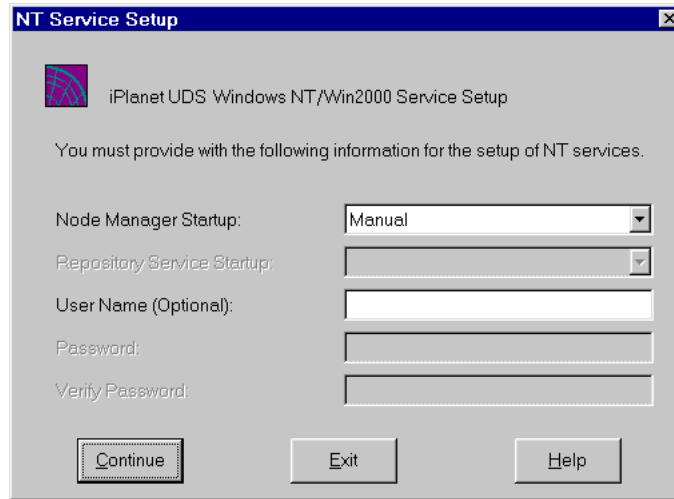

6. In the NT Service Setup dialog, specify how to set up NT services.

Specify Manual or Automatic for services. If you specify a User Name, then you must provide a password.

If you do not know what values to specify, simply accept the default values. You can change the values later using the Windows NT Control Panel. For more information on configuring Windows NT services, refer to your Windows NT documentation.

7. The setup program proceeds with the installation.

If you are installing with Administrator privileges, the setup program prompts you for the location for the iPlanet UDS program group. If you specify a *personal program group*, iPlanet UDS is only available to users with Administrator privileges. If you specify a *common program group*, then iPlanet UDS is available to all users.

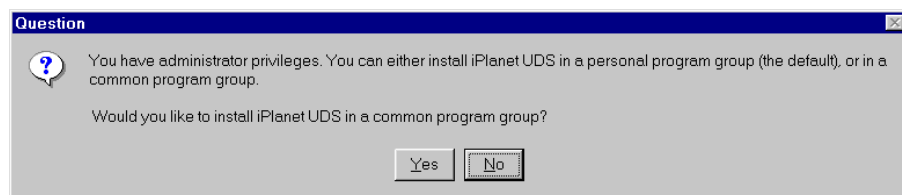

Click No for a personal program group

or

Click Yes for a common program group.

When the installation is complete, the setup program displays the Installation Complete dialog.

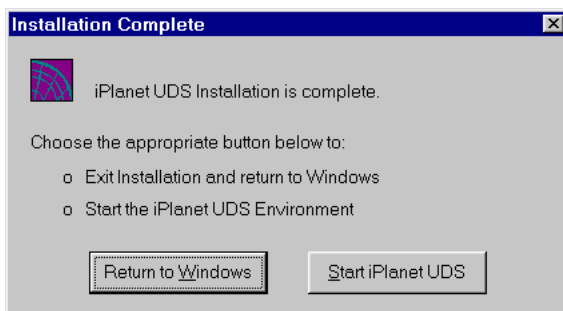

8. Click Return to Windows or Start iPlanet UDS to exit the setup program.

If you specify Start iPlanet UDS, iPlanet UDS runs against the examples repository created during installation (if you specified to install examples).

Proceed to [“After Installing iPlanet UDS” on page 82](#) for more information on your iPlanet UDS installation.

Installing iPlanet UDS–Runtime Only

Use the setup program on the *iPlanet UDS–Runtime Only CD* to install the iPlanet UDS–Runtime Only software. If you are installing iPlanet UDS software, refer to [“Installing iPlanet UDS” on page 66](#).

The setup program offers you the following installation options:

Option	Description
Full Installation	Installs iPlanet UDS and configures the target node as a runtime client node for an iPlanet UDS environment.
Uninstall iPlanet UDS	Uninstalls iPlanet UDS by removing all iPlanet UDS files from specified location.

You can only install a runtime client from the *iPlanet UDS–Runtime Only CD*. This section describes how to perform an iPlanet UDS–Runtime Only installation.

➤ **To install an iPlanet UDS runtime client**

1. From the *iPlanet UDS–Runtime Only CD*, start the setup program (available from the PC_W32 folder).

For information on silent mode installations, refer to [“Silent Installation” on page 65](#).

After displaying the splash screen and the license agreement, the setup program displays the Welcome dialog.

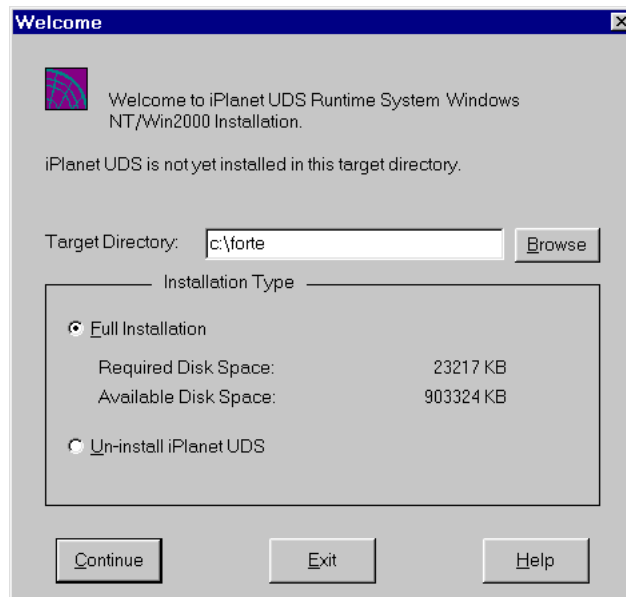

NOTE You can exit the setup program at any time by clicking Exit. However, exiting the installation before its completion may leave changes made by the installer in the Windows registry and iPlanet UDS files on your local disk. Run the setup program’s uninstall option to clean up the registry and to remove any installed iPlanet UDS files.

2. Specify a target directory for the iPlanet UDS installation

If the target directory you specify does not exist, the setup program creates it for you. The setup program creates the FORTE_ROOT environment variable based on your specification.

3. Select the Full Installation option and click Continue.

The setup program displays the Distributed Setup dialog, which prompts you for information about your iPlanet UDS environment.

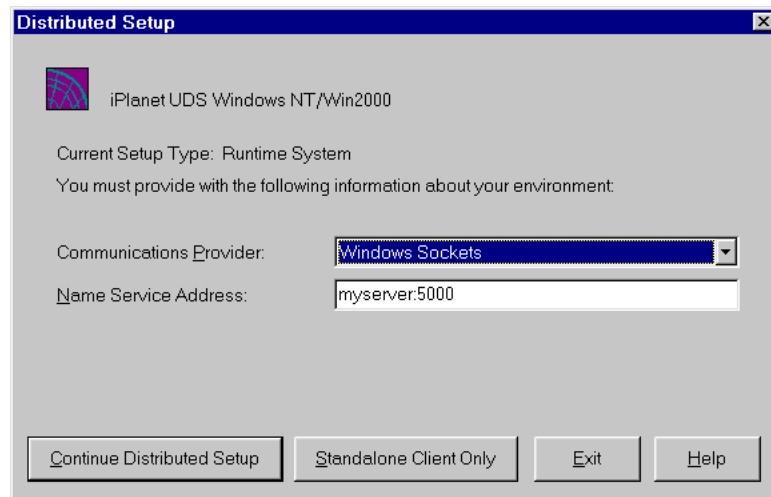
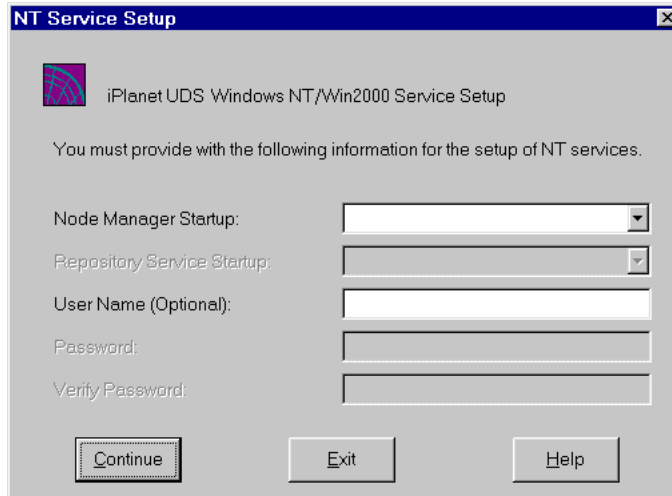

Table 3-3 on page 63 provides a description of the options available to you. If you do not know what values to specify, simply accept the default values. You can change the values later, either by using the iPlanet UDS Control Panel or by editing the Windows registry directly, as described in *A Guide to the iPlanet UDS Workshops*.

4. Specify values for the node's iPlanet UDS environment and click Continue Distributed Setup.

If you have Administrator privileges and Windows NT services were not previously installed, the setup program displays the NT Service dialog.



The setup program installs the iPlanet UDS Node Manager as a Windows NT service. For Node Manager Startup, specify Manual or Automatic. If you specify a User Name, then you must provide a password. For more information on configuring Windows NT services, refer to your Windows NT documentation.

5. Click Continue to proceed with the installation.

During the installation, the setup decompresses iPlanet UDS files, opens and closes iPlanet UDS components as necessary, and initializes iPlanet UDS.

If you are installing with Administrator privileges, the setup program prompts you for the location for the iPlanet UDS group. If you specify a *personal program group*, iPlanet UDS is only available to users with Administrator privileges. If you specify a *common program group* then iPlanet UDS is available to all users.

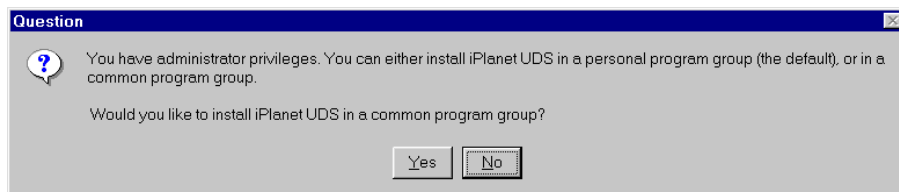

Click No for a personal program group

or

Click Yes for a common program group.

The installation proceeds to completion.

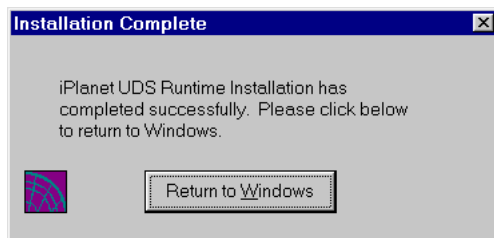

6. Click Return to Windows to exit the setup program.

Proceed to [“After Installing iPlanet UDS” on page 82](#) for more information on your iPlanet UDS installation.

After Installing iPlanet UDS

Your iPlanet UDS installation on Windows platforms contains the following components:

- FORTE_ROOT directory structure
- iPlanet UDS registry keys
- iPlanet UDS shortcuts

Depending on the installation option you choose—full or custom—the iPlanet UDS setup program installs a different subset of components onto your Windows NT node. The following table shows the components the setup program installs for each installation option:

Installation Option	Components Installed
Full Distributed <i>central server node</i>	<ul style="list-style-type: none"> • FORTE_ROOT directory structure • Complete set of fully defined iPlanet UDS registry keys • iPlanet UDS central server processes (environment manager and repository service), installed as Windows NT services and configured for automatic startup • iPlanet UDS example programs (installed in their own repository, named demo30, located in the %FORTE_ROOT%\repos directory) • iPlanet UDS diagnostic files, placed in the FORTE_ROOT directory structure • iPlanet UDS debugging files, placed in the FORTE_ROOT directory structure • Shortcuts to iPlanet UDS executables, placed in a Windows program group and made available from the Windows Start menu

Installation Option	Components Installed
Server <i>server node</i>	<ul style="list-style-type: none"> • FORTE_ROOT directory structure • Complete set of fully defined iPlanet UDS registry keys • iPlanet UDS server process (node manager) installed as Windows NT services, and configured for automatic startup • iPlanet UDS example programs (optional) (installed in their own repository, named demo30, located in the %FORTE_ROOT%\repos directory) • iPlanet UDS diagnostic files (optional), placed in the FORTE_ROOT directory structure • iPlanet UDS debugging files (optional), placed in the FORTE_ROOT directory structure • Shortcuts to iPlanet UDS executables, placed in a Windows program group and made available from the Windows Start menu
Custom: Client <i>Distributed</i>	<ul style="list-style-type: none"> • FORTE_ROOT directory structure • Complete set of fully defined iPlanet UDS registry keys • iPlanet UDS example programs (optional)—placed in the FORTE_ROOT directory structure • iPlanet UDS diagnostic files (optional)—placed in your FORTE_ROOT directory structure • Shortcuts to iPlanet UDS executables in your FORTE_ROOT directory structure placed in a Windows program group and made available from the Windows Start menu
Custom: Client <i>Standalone</i>	<ul style="list-style-type: none"> • FORTE_ROOT directory structure • Partial set of fully defined iPlanet UDS registry keys (FORTE_NS_ADDRESS key is not set) • iPlanet UDS example programs (optional) • iPlanet UDS diagnostic files (optional) • Shortcuts to iPlanet UDS executables, placed in a Windows program group and made available from the Windows Start menu
Runtime Client	<ul style="list-style-type: none"> • FORTE_ROOT directory structure
Files Only	<ul style="list-style-type: none"> • FORTE_ROOT directory structure

FORTE_ROOT Directory Structure

FORTE_ROOT is the directory you define as the target directory for your iPlanet UDS installation. The installation program sets the location of your FORTE_ROOT directory as the value of the FORTE_ROOT environment variable.

CAUTION Do not change the structure of the FORTE_ROOT directory. The directory structure must remain intact for iPlanet UDS to function properly—iPlanet UDS relies on the path links within the structure to locate and use iPlanet UDS components.

The setup program installs the FORTE_ROOT structure at the location you choose. You can later move the location of FORTE_ROOT, but you must keep the structure intact. If you do move the location of FORTE_ROOT, then you should change any iPlanet UDS environment variable that defines the location of files and directories in the structure. You can use the iPlanet UDS Control Panel to redefine these iPlanet UDS environment variables.

Table 3-7 describes the contents of the directory structure defined by FORTE_ROOT:

Table 3-7 Contents of the FORTE_ROOT directory

Directory	Content
appdist	Application and library distributions are created here when a developer makes a distribution, or placed here when you copy a distribution from a tape or other media in order to deploy the distribution. Refer to the <i>iPlanet UDS System Management Guide</i> for more information.
envdist	Environment definitions are placed here when they are exported from the environment repository. Refer to the <i>iPlanet UDS System Management Guide</i> for more information.
external	Used as a place to put external libraries. This directory is empty at installation.
install	This directory contains installed iPlanet UDS software, as described in Table 3-8.
log	System and application log files are written here.
repos	Development repositories are created and stored here. This is the most critical directory to back up.
sysdata	This data contains information important to the iPlanet UDS runtime system and iPlanet UDS system management applications.

Table 3-7 Contents of the FORTE_ROOT directory (*Continued*)

Directory	Content
tmp	This directory is used as a temporary holding directory when making an application or library distribution that contains compiled components.
userapp	Application partitions and libraries are installed here by iPlanet UDS during the deployment process. Only application partitions that run on a particular node are installed in the userapp directory of that node.
userlib	When building an application, this directory is created to hold compiled libraries for the application. This directory does not exist when you first install Forte.
workmsg	This directory is used for working copies of message files for international language support. This directory is empty at installation.

Install Directory under FORTE_ROOT

The install directory under FORTE_ROOT contains programs, libraries, and other files used to run an iPlanet UDS system, including:

- executable files
- iPlanet UDS dynamically linked libraries
- seed repositories
- example programs (if installed)
- scripts
- diagnostic tools

Table 3-8 describes the contents of the FORTE_ROOT\install directory:

Table 3-8 FORTE_ROOT/install Directory Contents

Directory	Content
bin	iPlanet UDS system executables.
diag	Diagnostic tools used by iPlanet UDS technical support.
examples	Sample projects and examples provided by iPlanet UDS.
inc	(Development only) Header and template files used for C++ code generation and 3GL integration.
lib	C and C++ shared libraries used by iPlanet UDS system executables.

Table 3-8 FORTE_ROOT/install Directory Contents (*Continued*)

Directory	Content
nls	Internationalization files.
reposcpy	iPlanet UDS development system seed repository used by the system when creating new repositories and the iPlanet UDS system repository.
scripts	iPlanet UDS scripts, some of which the installer program uses in installing iPlanet UDS on your node, and others which you can use or adapt to automate iPlanet UDS tasks, such as starting and stopping iPlanet UDS and iPlanet UDS components.

iPlanet UDS Registry Keys

If you install iPlanet UDS with Administrator privileges, the iPlanet UDS setup program defines a set of keys in the HKEY_LOCAL_MACHINE hive of the Windows registry as iPlanet UDS environment variables. If instead you install using User privileges, the setup program adds these Registry changes to your HKEY_CURRENT_USER hive.

iPlanet UDS uses these keys to configure such things as connecting your node to the services of an iPlanet UDS environment, and governing internal operations strictly local to your node. Each key is defined as a text string.

The following table lists some of the environment variables created by the iPlanet UDS installer for Windows installations.

Table 3-9 iPlanet UDS Environment Variables (WIndows NT)

iPlanet UDS Key	Definition	Default Value
FORTE_LOGGER_SETUP	<p>A string defining how iPlanet UDS keeps logs of your use of iPlanet UDS.</p> <p>You can use the iPlanet UDS logging facility to track many kinds of iPlanet UDS processes, to isolate problems in iPlanet UDS itself, and in iPlanet UDS applications that you develop.</p> <p>When you start iPlanet UDS, the runtime system consults this key to determine what logging processes to implement.</p> <p>For more information on how to use iPlanet UDS log files and the iPlanet UDS logging facilities, see <i>iPlanet UDS System Management Guide</i>.</p>	%stdout(err:sh:*)

Table 3-9 iPlanet UDS Environment Variables (Windows NT) (*Continued*)

iPlanet UDS Key	Definition	Default Value
FORTE_NS_ADDRESS	<p>The iPlanet UDS name service address for your node. The address of the name service for the iPlanet UDS environment to which you are connecting your node. The name service is an iPlanet UDS process running on the iPlanet UDS environment's central server node, governing iPlanet UDS communication among nodes in the environment.</p> <p>The address itself consists of two parts, separated by a colon, as in <i>myserver:5000</i>, the default value. The first part of the address is the network name of the central server node, and the second part is a number between 1025 and 9000, inclusive.</p>	<i>myserver:5000</i>
FORTE_REPOSNAME	The name of a central development repository for the environment.	CentralRepository
FORTE_ROOT	<p>The FORTE_ROOT directory contains your iPlanet UDS installation: the executables and data files that compose the iPlanet UDS system.</p> <p>For more information about the contents of the FORTE_ROOT directory structure, see "FORTE_ROOT Directory Structure" on page 84.</p>	c:\forte
PATH <i>Environment variable, (but not a registry key)</i>	Updated to include the path to your iPlanet UDS executables located in subdirectories of the FORTE_ROOT directory.	The path to the file in your FORTE_ROOT directory: FORTE_ROOT\install\bin

NT Services

When installing with Administrator privileges, the setup program installs the iPlanet UDS repository manager and environment manager as Windows NT services. During the installation, you choose how to configure the services.

To view the NT services, from the Windows Control Panel, double-click the Services icon.

Figure 3-1 iPlanet UDS Services as Windows NT Services

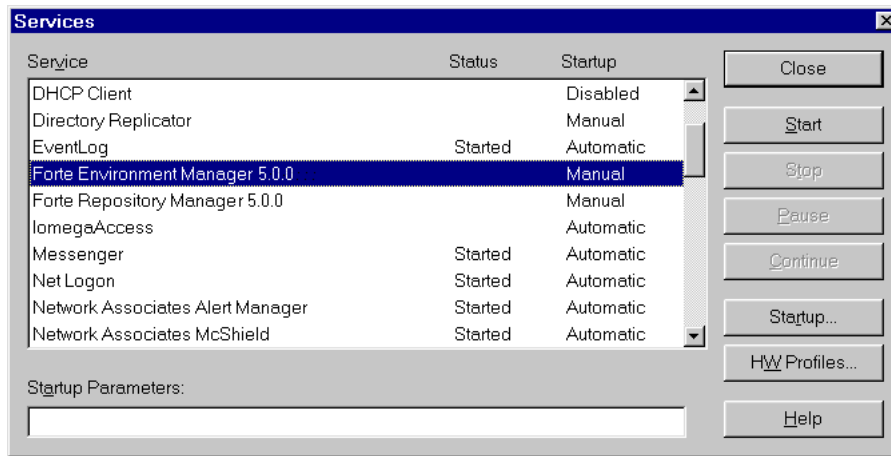

For more information on configuring Windows NT services, see your Windows NT documentation.

iPlanet UDS Program Group and Shortcuts

The setup program creates a Windows program group for your iPlanet UDS installation. The program group contains Windows shortcuts you can use to start and administer iPlanet UDS. Each shortcut corresponds to an iPlanet UDS application—either an executable in the %FORTE_ROOT%\install\bin directory, or an iPlanet UDS image repository in the %FORTE_ROOT%\userapp directory.

Figure 3-2 iPlanet UDS Program Group (Windows NT)

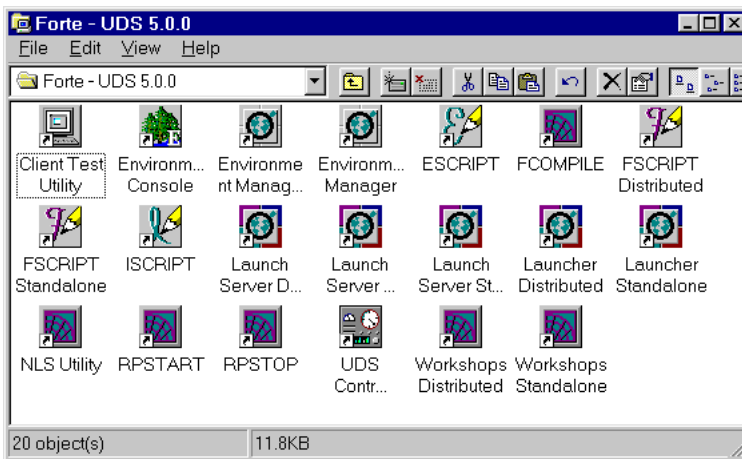

The iPlanet UDS shortcuts from the program group are also available from the Windows Start menu, under Programs > Forte - UDS.

Workshops Distributed Shortcut

The Workshops Distributed Shortcut, pictured below opens the iPlanet UDS development workshops.



Figure 3-3 below shows the properties of the iPlanet UDS Distributed shortcut. The shortcut tab illustrates the command path and command to start the FTCMD.EXE executable, which starts the iPlanet UDS Launch Server. For information on how the Launch Server works to run iPlanet UDS applications, and on how you can configure the Launch Server to run iPlanet UDS applications that you develop, refer to the *iPlanet UDS System Management Guide*.

Figure 3-3 iPlanet UDS Distributed Shortcut (Windows NT)

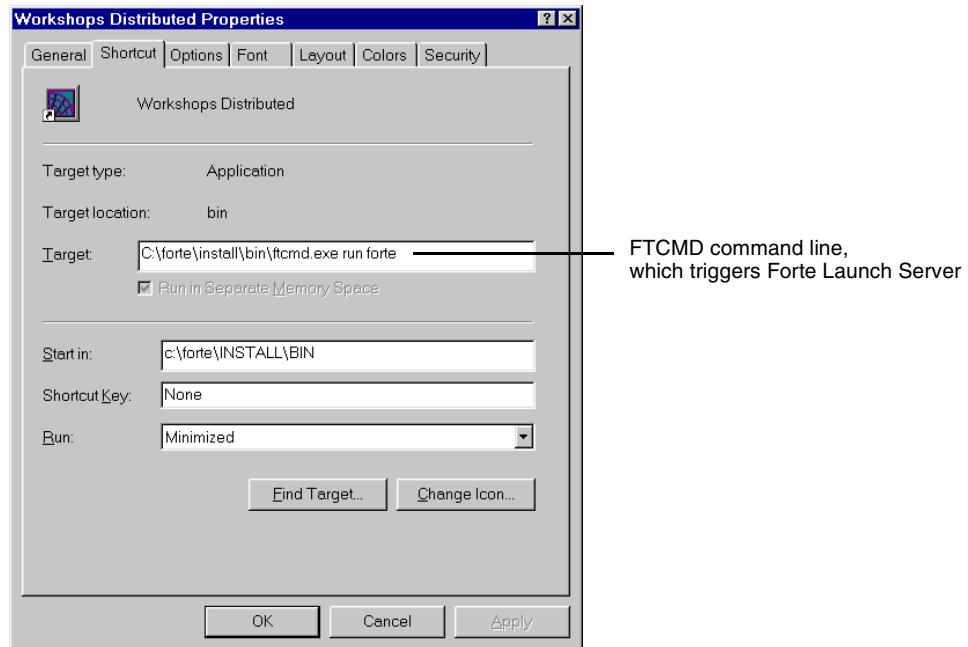

The following table defines the targets for the shortcuts in the iPlanet UDS program group. Each target is located within the %FORTE_ROOT%\install\bin directory.

Table 3-10 Windows Shortcuts for iPlanet UDS

Shortcut	Target (<i>FORTE_ROOT</i> \install\bin...)
Client Test Utility	FTCMD.EXE run ClientTester
Environment Console	FTCMD.EXE run EnvironmentConsole
Environment Manager	NODEMGR.EXE -e centrale
Environment Manager Shutdown	FTEXEC.EXE -fcons -fi -bt:FORTE_ROOT:\forte\USERAPP\ESCRIP\CL0\ESCRIP -i FORTE_ROOT:\forte\INSTALL\SCRIPTS\SHUTDOWN.SCR
ESCRIP	FTEXEC.EXE -fcons -fi bt:FORTE_ROOT\USERAPP\ESCRIP\CL0\ESCRIP -fnw
F_COMPILE	FTEXEC.EXE -fcons -fs -fi bt:FORTE_ROOT\USERAPP\FTCOMPIL\CL0\F_COMPILE
FSCRIPT Distributed	FTEXEC.EXE -fcons -fi bt:FORTE_ROOT\USERAPP\FSCRIPT\c17\FSCRIPT -fw FirstWorkspace -fnict
FSCRIPT Standalone	FTEXEC.EXE -fs -fcons -fi bt:FORTE_ROOT\USERAPP\FSCRIPT\c17\FSCRIPT -fw FirstWorkspace -fnict
ISCRIP	ISCRIP.EXE
Launch Server Distributed	FTEXEC.EXE -fss -fi bt:FORTE_ROOT\USERAPP\FTLAUNCH\CL0\FTLAUNCH
Launch Server Shutdown	FTCMD.EXE shutdown server
Launch Server Standalone	FTEXEC.EXE -fs -fss -fi bt:FORTE_ROOT\USERAPP\FTLAUNCH\CL0\FTLAUNCH
Launcher Distributed	FTCMD.EXE run launcher
Launcher Standalone	FTCMD.EXE -fs run launcher
NLS Utility	FTEXEC.EXE -fs -fi bt:FORTE_ROOT\USERAPP\NLSUTIL\CL0\NLSUTIL
NODEMGR	NODEMGR.EXE

Table 3-10 Windows Shortcuts for iPlanet UDS (*Continued*)

Shortcut	Target (<i>FORTE_ROOT\instal\bin...</i>)
RPSTART	RPSTART.EXE -fr bt:central -n CentralRepository
RPSTOP	RPSTOP.EXE -n CentralRepository
UDS Control Panel	FTEXEC.EXE -fs -fss -fi bt: <i>FORTE_ROOT</i> :\FORTE\USERAPP\ENVIRONM\CL0\FCONTROL
Workshops Distributed	FTCMD.EXE run forte
Workshops Standalone	FTEXEC.EXE -fs -fss -fi bt: <i>FORTE_ROOT</i> :\FORTE\USERAPP\FORTE\CL0\FORTE

NOTE Most shortcuts invoke the FTCMD or FTEXEC executables (iPlanet UDS application launching processes), passing command lines arguments to them. For more information on building iPlanet UDS command lines for iPlanet UDS utilities, refer to the *iPlanet UDS System Management Guide*. For a detailed description of the iPlanet UDS application launching system, including instructions on how to use it, refer to the *iPlanet UDS Programming Guide*.

Installing iPlanet UDS on Windows 98/95 Nodes

This chapter describes how to install iPlanet UDS software and iPlanet UDS–Runtime Only software on Windows 98 and Windows 95 platforms. This chapter also discusses configuring a Windows 98/95 node once you complete installation. The instructions and information in this chapter refer to Windows 98 throughout. However, the instructions and information apply equally to Windows 95.

Note that Windows 98 is certified only as a platform for deployment and development of iPlanet UDS applications. Refer to [Chapter 3, “Installing iPlanet UDS on Windows NT and Windows 2000 Nodes,”](#) for information on installing server nodes on Windows NT and Windows 2000.

iPlanet UDS software is installed from the *iPlanet UDS Platform CD*. iPlanet UDS–Runtime Only software is installed from the *iPlanet UDS–Runtime Only CD*. For information on iPlanet UDS and iPlanet UDS–Runtime Only software, and on the iPlanet UDS CDs, refer to [“Installation Media” on page 33](#).

Refer to the platform matrix at <http://www.forte.com/support/platforms.html> for the requirements for this release.

This chapter contains the following sections:

- [“Preparing for an iPlanet UDS Installation” on page 94](#)
- [“Installing the Software” on page 97](#)
- [“After Installing iPlanet UDS” on page 111](#)

Preparing for an iPlanet UDS Installation

Before beginning an iPlanet UDS installation, you should read **Chapter 1 on page 25**. **Chapter 1** provides background information on iPlanet UDS that is helpful to planning and installing iPlanet UDS and iPlanet UDS–Runtime Only software. You should also be familiar with information in the *iPlanet UDS System Management Guide* that describes how to set up and maintain an iPlanet UDS system.

Platform Matrix

iPlanet UDS has critical dependencies on operating systems, windowing systems, networking systems, runtime libraries, and database management systems. Before installing iPlanet UDS system software, consult the platform matrix (at <http://www.forte.com/support/platforms.html>) to make sure the target platform meets the requirements for this release.

Your system must meet the minimal requirements for the following components:

Component	Comments
Operating system	The versions of Microsoft Windows supported.
Windowing system	For Microsoft platforms, this is the native windowing system.
Networking system	Nodes with distributed installations must be able to ping server nodes.
C++ compiler	Required if you intend to integrate 3GL programs with iPlanet UDS applications or create compiled partitions and libraries.
External interface	Required if you plan distributed access using third party tools.

Types of Installations

“Setting up an iPlanet UDS Environment” on page 28 discusses the types of nodes in an iPlanet UDS environment. During installation, you select the type of node you are installing and provide information during the installation process. For complete information about setting up an iPlanet UDS environment, refer to the *iPlanet UDS System Management Guide*.

The following tables list the types of nodes in an iPlanet UDS environment that are supported for Windows 98 nodes. They also lists the information you need to supply the installation program. “iPlanet UDS Environment” on page 96 provides descriptions of the information listed in these tables.

Table 4-1 Nodes in an iPlanet UDS Environment (Windows 98)

Node	Node Property and Other Information
Client (Distributed)	Target directory iPlanet UDS Name Service address Distributed repository name Example applications
Client Node (Standalone)	Target directory Example applications
iPlanet UDS files	This option copies only the iPlanet UDS directory structure and source files to the target node, leaving the node setup for later.

Table 4-2 Nodes in an iPlanet UDS–Runtime Only Environment (Windows 98)

Node	Node Property and Other Information
iPlanet UDS Runtime Client	Target directory iPlanet UDS Name Service address

iPlanet UDS Environment

During the installation process, the setup program prompts you for information about your iPlanet UDS environment. Using the information you provide, setup creates iPlanet UDS keys in the system registry (also known as iPlanet UDS environment variables). The information you provide the setup program depends on the type of iPlanet UDS node you are installing. The following table describes the information you need to provide the installer.

Table 4-3 Information Required to Install iPlanet UDS (Windows 98)

Nodes/Information	Description	Default Value
Target directory <i>all nodes</i>	The root directory of your iPlanet UDS installation. The setup program creates the FORTE_ROOT environment variable based on this location.	C:\forte
Communications Provider <i>client (distributed) runtime client</i>	The communications interface the Windows client uses to run iPlanet UDS. On Windows NT, iPlanet UDS supports the Windows Sockets interface exclusively, so you do not need to change the default.	Windows Sockets
Name Service Address <i>client (distributed) runtime client</i>	<p>The address of the name service for the iPlanet UDS environment you are establishing. The name service is an iPlanet UDS process running on the central server node you are installing. The name service governs iPlanet UDS communication among nodes in the environment.</p> <p>The address consists of the network name of the central server node and the specified port ID, separated by a colon (for example, <i>myserver:5000</i>). The port ID must be a number between 1025 and 65536 inclusive.</p> <p>You should be able to ping the server by name if the name is part of the name service address, or by the IP address if the IP address is part of the name service address.</p> <p>The setup program inserts the value you specify into your Windows registry as the value of the FORTE_NS_ADDRESS key in either the HKEY_LOCAL_MACHINE hive (installing with Administrator privileges) or the HKEY_CURRENT_USER hive (installing with User privileges). You can later change this value to connect your node to a different environment by changing the environment variable yourself.</p> <p>For a full description of the changes the setup program makes to your Registry, see “iPlanet UDS Registry Keys” on page 114.</p>	<i>myserver:5000</i>

Table 4-3 Information Required to Install iPlanet UDS (Windows 98) (*Continued*)

Nodes/Information	Description	Default Value
Central repository name <i>client (distributed)</i>	The name of the central development repository the node maintains in its iPlanet UDS environment for collaborative application development.	CentralRepository

Installing the Software

This section describes the installation procedures to install iPlanet UDS and iPlanet UDS–Runtime Only software. The installation setup program is available from the distribution CD.

For information on the differences between the iPlanet UDS and iPlanet UDS–Runtime Only, refer to [“About iPlanet UDS” on page 25](#).

For information on accessing the iPlanet UDS CDs, and the location of the setup program, refer to [“Installation Media” on page 33](#).

NOTE You cannot install onto a remote disk—the target disk must be directly attached to the target node.

The process for installing iPlanet UDS and iPlanet UDS–Runtime Only software is the same for all supported Windows platforms. Use the setup program to install iPlanet UDS or any of its components, upgrade previous iPlanet UDS installations, or uninstall iPlanet UDS or any of its components.

Silent Installation

The setup program for installing iPlanet UDS on Windows platforms contains a *silent mode* option that allows you to install the software without user interaction. Before you can invoke the silent mode option, you must first perform an interactive install using the *record mode* option. The record mode option creates a `setup.iss` file that contains information for the silent mode option. This file can then be used for subsequent installations.

The following procedures show how to install using the record mode and install mode options. Before performing these procedures, make sure you read the installation instructions contained in this chapter.

➤ **To perform a record mode installation**

1. Run the setup program on the *iPlanet UDS* distribution CD with the following options:

```
setup -r [ -f1path\setup.iss ]
```

path specifies the path to a location for the `setup.iss` file. If you do not specify a path to the `setup.iss` file, the file is created in your Windows directory.

➤ **To perform a silent mode installation**

1. If you have not run a record mode installation, run the record mode installation to create a `setup.iss` file.

This file must be created before you can run the installation in silent mode.

2. Run the setup program on the *iPlanet UDS* distribution CD with the following options:

```
setup -s -f1path1\setup.iss [ -f2path2\setup.log ]
```

path1 specifies the path to the location of the `setup.iss` file.

path2 specifies the path to a location for the `setup.log` file.

3. If you created a `setup.log` file, examine it to determine if the installation was successful.

If the installation was successful, `setup.log` contains the following line:

```
ResultCode=0
```

Installing iPlanet UDS

Use the setup program on the *iPlanet UDS Platform CD* to install the iPlanet UDS software. If you are installing iPlanet UDS–Runtime Only software, refer to [“Installing iPlanet UDS–Runtime Only” on page 108](#).

The setup program offers you the installation options listed in [Table 4-4](#).

Table 4-4 Windows 98 Installation Options

Option	Description
Full Distributed Installation	Installs iPlanet UDS and configures your node for distributed participation in an iPlanet UDS environment, establishing iPlanet UDS environment variable settings in your Windows 95 registry for this purpose.
Custom Installation	Provides options for installing any (or all) of three iPlanet UDS components: <ul style="list-style-type: none"> • iPlanet UDS Development System (the iPlanet UDS software) • Examples (iPlanet UDS Example Programs) • Diagnostic Tools (tools for evaluating problems in your iPlanet UDS environment with help from the iPlanet UDS technical support team.) • Debug Files (files for evaluating problems in your iPlanet UDS environment with help from the iPlanet UDS technical support team.)
Uninstall iPlanet UDS	Uninstalls iPlanet UDS by removing all iPlanet UDS files from specified location.

The following sections provide installation procedures for a full distributed installation and a custom installation.

Installation Procedures

This section contains procedures for the following types of iPlanet UDS installations:

- [“Full Distributed Installation”](#) below
- [“Custom Installation”](#) on page 102

Full Distributed Installation

This section describes how to perform a full distributed iPlanet UDS installation—the iPlanet UDS setup program installs and configures your node for distributed participation in iPlanet UDS environment.

➤ **To perform a standard, full distributed iPlanet UDS installation**

1. From the *iPlanet UDS Platform CD*, start the setup program (available from the PC_W32 folder).

For information on silent mode installations, refer to “[Silent Installation](#)” on [page 97](#).

After displaying the splash screen and the license agreement, the setup program displays the Welcome dialog.

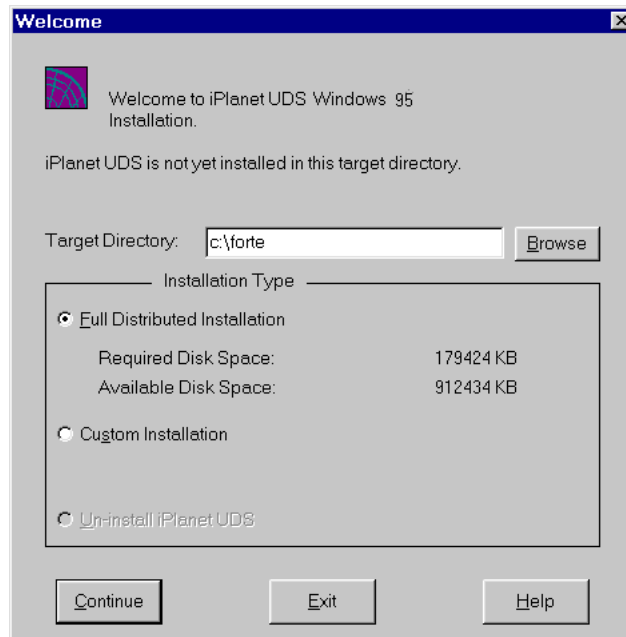

NOTE You can exit the setup program at any time by clicking Exit. However, exiting the installation before its completion may leave changes made by the installer in the Windows registry and iPlanet UDS files on your local disk. Run the setup program's uninstall option to clean up the registry and to remove any installed iPlanet UDS files.

2. Specify a target directory for the iPlanet UDS installation

If the target directory you specify does not exist, the setup program creates it for you. The setup program creates the FORTE_ROOT environment variable based on your specification.

3. Select Full Distributed Installation option and click Continue.

The setup program displays the Distributed Setup dialog, which prompts you for information about your iPlanet UDS environment.

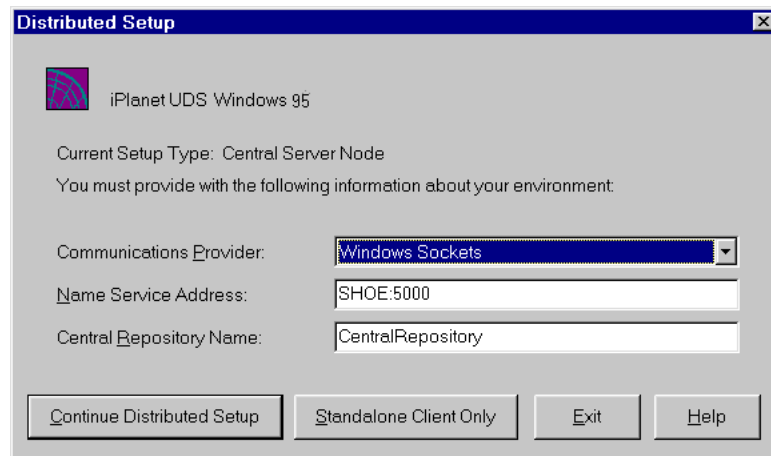

Table 4-3 on page 96 provides a description of the options available to you. If you do not know what values to specify, simply accept the default values. You can change the values later, either by using the iPlanet UDS Control Panel or by editing the Windows registry directly, as described in *A Guide to the iPlanet UDS Workshops*.

4. Specify values for the node's iPlanet UDS environment and click Continue Distributed Setup.

If you click Standalone Client Only, the setup program ignores the specifications in the Distributed Setup dialog and instead continues with a standalone client installation.

5. The setup program proceeds with the installation.

The setup program creates an iPlanet UDS program group and installs shortcuts in the Windows Start menu for starting and administering iPlanet UDS.

When the distributed setup installation is complete, the setup program displays the Installation Complete dialog.

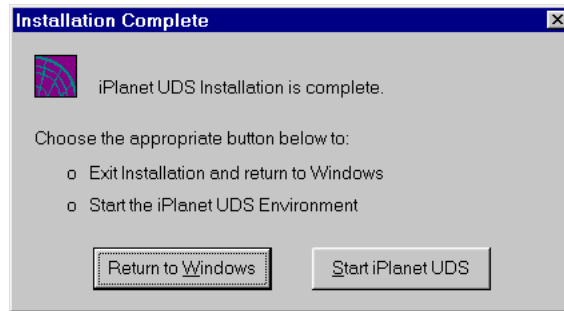

6. Click Return to Windows or Start Forte to exit the setup program.

If you start iPlanet UDS, iPlanet UDS connects to the examples repository created during installation.

Proceed to **“After Installing iPlanet UDS” on page 111** for more information on your iPlanet UDS installation.

Custom Installation

This section describes how to perform a custom installation of iPlanet UDS software. A custom installation option provides more flexibility when installing iPlanet UDS.

Table 4-5, below, summarizes the types of installations available when you choose the custom installation option. For more information on each type, refer to **“Types of Installations” on page 95**.

Table 4-5 Types of Custom Installations (Windows 98)

Setup Type	Description
Client Only (Distributed)	<p>Installs iPlanet UDS, and configures the node for participation in an iPlanet UDS environment, establishing appropriate iPlanet UDS settings in the Windows registry.</p> <p>This option differs from the default Full Distributed Installation only in allowing you to exclude the iPlanet UDS examples and iPlanet UDS diagnostic tools from the installation.</p>

Table 4-5 Types of Custom Installations (Windows 98) (*Continued*)

Setup Type	Description
Client Only (Standalone)	Installs iPlanet UDS and prepares the node to run without connection to an iPlanet UDS environment. Unlike the Client Only (Distributed) option, this option does not add iPlanet UDS networking information to the Windows registry. (For information on the changes the setup program makes to the Windows registry, refer to “ iPlanet UDS Registry Keys ” on page 114.)
Install Only	Installs only the iPlanet UDS files on your system, leaving you to configure iPlanet UDS on your own. This option does not create shortcuts for using iPlanet UDS, nor does it make any changes to the Windows registry.

In a custom installation, you can specify the following components to install. Not all components are available for all installation options.

Table 4-6 Custom Installation Components

Option	Description
iPlanet UDS Development System	The files necessary to run the iPlanet UDS development system. (This option cannot be disabled.)
iPlanet UDS examples	Several iPlanet UDS example programs that illustrate how to use TOOL and the iPlanet UDS classes. Examples are installed in the %FORTE_ROOT%\install directory and consist of .pex (iPlanet UDS project export) files and other related data files. Additionally, the examples are imported into a special repository, demo30, in the %FORTE_ROOT%\repos directory. For more information on the example programs, refer to the manual, <i>A Guide to the iPlanet UDS Workshops</i> .
iPlanet UDS diagnostic tools	Tools for evaluating problems (with help from the iPlanet UDS technical support team) in your iPlanet UDS environment.
iPlanet UDS debug files	Debugging files, each one a companion to an iPlanet UDS executable or dynamically linked library. These files are debugging tools for use by iPlanet UDS engineers in evaluating system problems; they are not necessary for using iPlanet UDS software. You can install them at any time by restarting the setup program.

NOTE You can bypass automatic configuration of your iPlanet UDS environment during setup, and instead accept the default values. After completing the installation, you can specify the iPlanet UDS environment settings from the UDS Control Panel or by editing the Windows registry.

➤ **To perform a custom iPlanet UDS installation**

1. From the *iPlanet UDS Platform CD*, start the setup program (available from the PC_W32 folder).

For information on silent mode installations, refer to [“Silent Installation” on page 97](#).

After displaying the splash screen, the setup program displays the Welcome dialog.

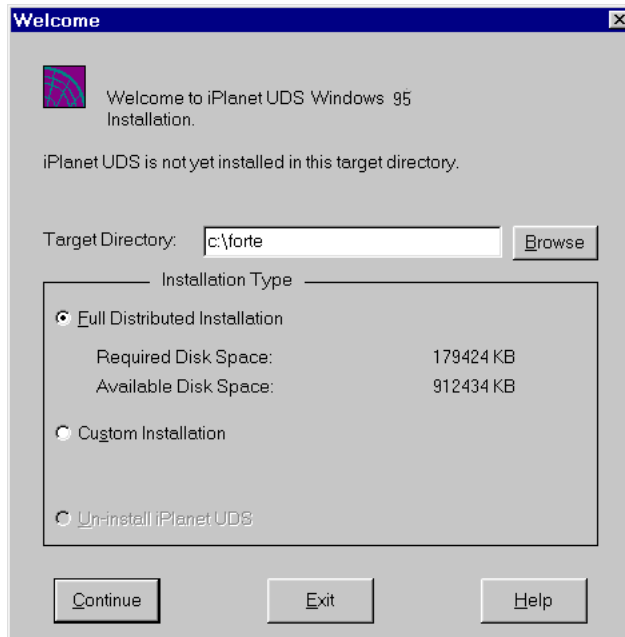

NOTE You can exit the setup program at any time by clicking Exit. However, exiting the installation before its completion may leave changes made by the installer in the Windows registry and iPlanet UDS files on your local disk. Run the setup program's uninstall option to clean up the registry and to remove any installed iPlanet UDS files.

2. Specify a target directory for the iPlanet UDS installation

If the target directory you specify does not exist, the setup program creates it for you. The setup program creates the FORTE_ROOT environment variable based on your specification.0

3. Select the Custom Installation option, then click Continue.

The setup program displays the Custom Installation dialog, which prompts you for the type of installation you are performing and for additional components to install.

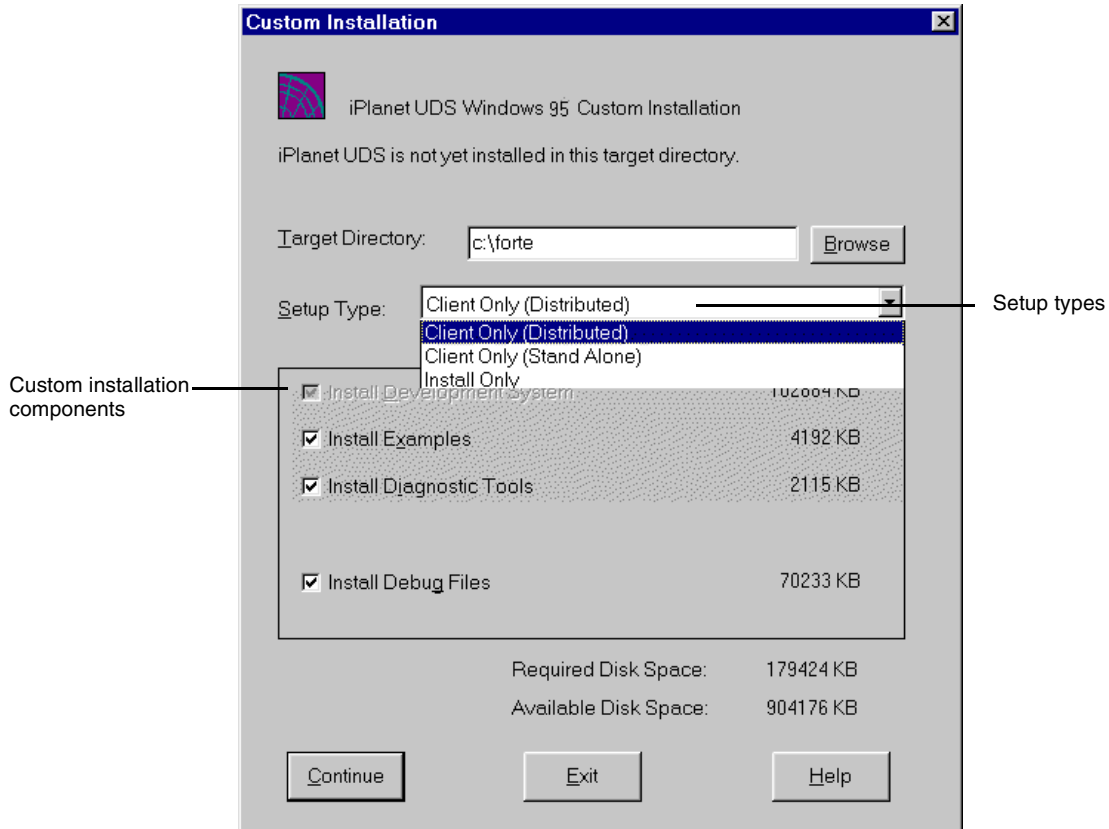

Table 4-5 on page 102 summarizes the types of installations you can perform. For additional information on each setup type, refer to “Types of Installations” on page 95.

Table 4-6 on page 103 describes the custom installation components.

4. Select the setup type and custom installation components to install, and then click Continue.

If you selected the Client Only (Standalone) option or the Install Files Only option, there are no additional specifications—the setup program begins the installation. Proceed to [Step 6 on page 108](#).

If you selected a (distributed) node the installer displays the Distributed Setup dialog.

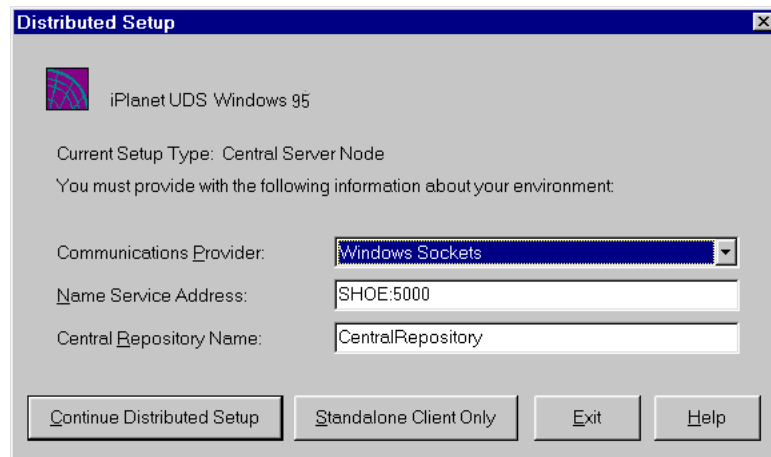

[Table 4-3 on page 96](#) describes the Distributed Setup options.

5. In the Distributed Setup dialog, enter the appropriate values for the target node and then click either Continue Distributed Setup or Standalone Client Only.

If you click Standalone Client Only, the setup program ignores the specifications in the Distributed Setup dialog and instead continues with a standalone client installation.

If you do not know what to specify for a distributed setup, proceed with the default values. After installation is complete, you can add the correct values either by using the iPlanet UDS Control Panel or by editing the Windows registry.

- The setup program proceeds with the installation.

When the installation is complete, the setup program displays the Installation Complete dialog.

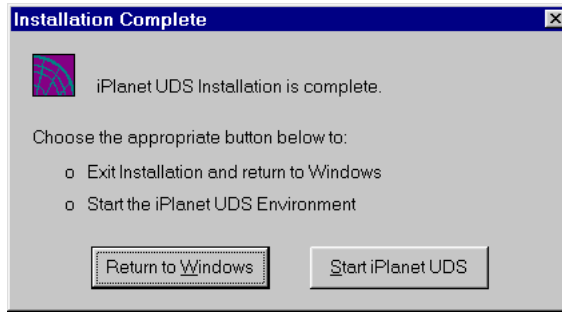

- Click Return to Windows or Start Forte to exit the setup program.

If you specify Start iPlanet UDS, iPlanet UDS runs against the examples repository created during installation (if you specified to install examples).

Proceed to [“After Installing iPlanet UDS” on page 111](#) for more information on your iPlanet UDS installation.

Installing iPlanet UDS–Runtime Only

Use the setup program on the *iPlanet UDS–Runtime Only CD* to install iPlanet UDS–Runtime Only software. If you are installing iPlanet UDS software, refer to [“Installing iPlanet UDS” on page 98](#).

The setup program offers you the following installation options:

Option	Description
Full Installation	Installs iPlanet UDS and configures the target node as a runtime client node for an iPlanet UDS environment.
Uninstall iPlanet UDS	Uninstalls iPlanet UDS by removing all iPlanet UDS files from specified location.

You can only install a runtime client from the *iPlanet UDS–Runtime Only CD*. This section describes how to perform an iPlanet UDS–Runtime Only installation.

► **To install an iPlanet UDS runtime client**

1. From the *iPlanet UDS Runtime Environment CD*, start the setup program.

For information on silent mode installations, refer to “[Silent Installation](#)” on [page 97](#).

After displaying the splash screen and the license agreement, the setup program displays the Welcome dialog.

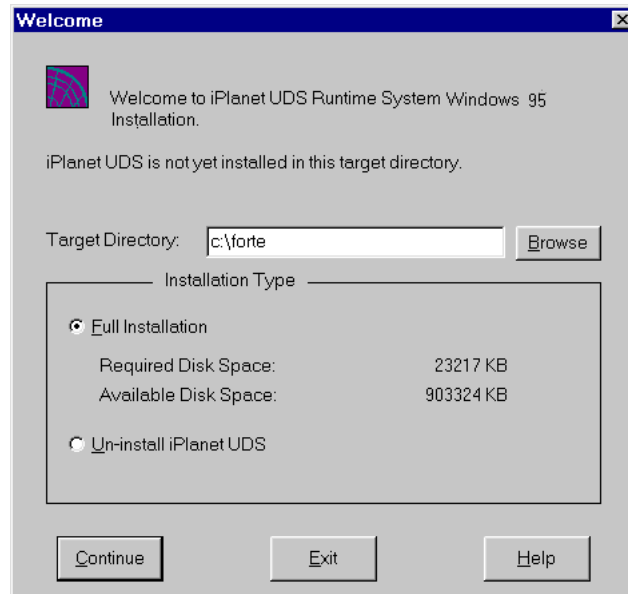

NOTE

You can exit the setup program at any time by clicking Exit. However, exiting the installation before its completion may leave changes made by the installer in the Windows registry and iPlanet UDS files on your local disk. Run the setup program’s uninstall option to clean up the registry and to remove any installed iPlanet UDS files.

2. Specify a target directory for the iPlanet UDS installation

If the target directory you specify does not exist, the setup program creates it for you. The setup program creates the FORTE_ROOT environment variable based on your specification.

3. Select the Full Installation option and click Continue.

The setup program displays the Distributed Setup dialog, which prompts you for information about your iPlanet UDS environment.

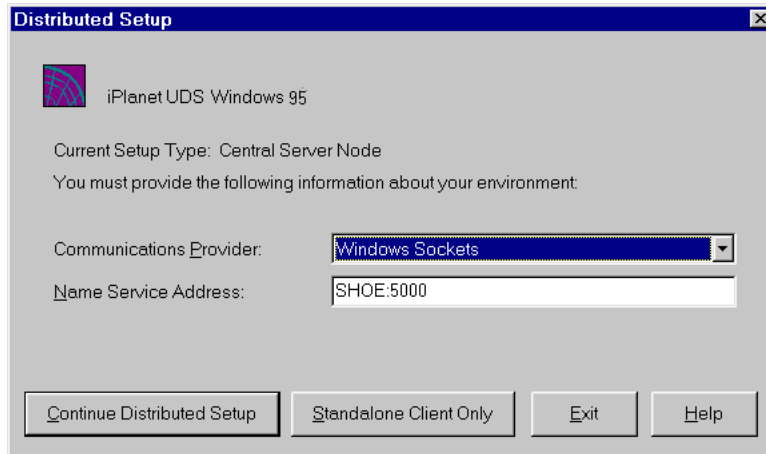
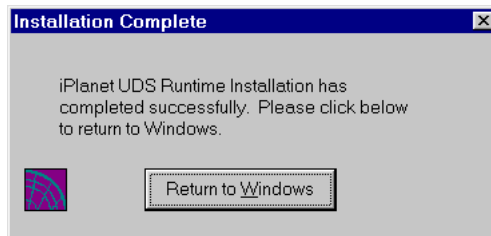

Table 4-3 on page 96 provides a description of the options available to you. If you do not know what values to specify, simply accept the default values. You can change the values later, either by using the iPlanet UDS Control Panel or by editing the Windows registry directly, as described in *A Guide to the iPlanet UDS Workshops*.

4. Specify values for the node's iPlanet UDS environment and click Continue Distributed Setup.

During the installation, the setup decompresses iPlanet UDS files, opens and closes iPlanet UDS components as necessary, and initializes iPlanet UDS.

The installation proceeds to completion.



5. Click Return to Windows to exit the setup program.

Proceed to “[After Installing iPlanet UDS](#)” below for more information on your iPlanet UDS installation.

After Installing iPlanet UDS

Your iPlanet UDS installation on Windows platforms contains the following components:

- FORTE_ROOT directory structure
- iPlanet UDS registry keys
- iPlanet UDS shortcuts

Depending on the installation option you choose—full or custom—the iPlanet UDS setup program installs a different subset of components onto your Windows NT node. The following table shows the components the setup program installs for each installation option:

Installation Option	Components Installed
Client <i>Distributed</i>	<ul style="list-style-type: none"> • FORTE_ROOT directory structure • Complete set of fully defined iPlanet UDS registry keys • iPlanet UDS example programs (optional)—placed in the FORTE_ROOT directory structure • iPlanet UDS diagnostic files (optional)—placed in your FORTE_ROOT directory structure • Shortcuts to iPlanet UDS executables in your FORTE_ROOT directory structure
Client <i>Standalone</i>	<ul style="list-style-type: none"> • FORTE_ROOT directory structure • Partial set of fully defined iPlanet UDS registry keys (FORTE_NS_ADDRESS key is not set) • iPlanet UDS example programs (optional) • iPlanet UDS diagnostic files (optional) • Shortcuts to iPlanet UDS executables, placed in a Windows program group and made available from the Windows Start menu
Runtime Client	<ul style="list-style-type: none"> • FORTE_ROOT directory structure
Files Only	<ul style="list-style-type: none"> • FORTE_ROOT directory structure

FORTE_ROOT Directory Structure

FORTE_ROOT is the directory you define as the target directory for your iPlanet UDS installation. The installation program sets the location of your FORTE_ROOT directory as the value of the FORTE_ROOT environment variable.

CAUTION Do not change the structure of the FORTE_ROOT directory. The directory structure must remain intact for iPlanet UDS to function properly—iPlanet UDS relies on the path links within the structure to locate and use iPlanet UDS components.

The setup program installs the FORTE_ROOT structure at the location you choose. You can later move the location of FORTE_ROOT, but you must keep the structure intact. If you do move the location of FORTE_ROOT, then you should change any iPlanet UDS environment variable that defines the location of files and directories in the structure. You can use the iPlanet UDS Control Panel to redefine these iPlanet UDS environment variables.

Table 4-7 describes the contents of the directory structure defined by FORTE_ROOT:

Table 4-7 Contents of the FORTE_ROOT directory

Directory	Content
appdist	Application and library distributions are created here when a developer makes a distribution, or placed here when you copy a distribution from a tape or other media in order to deploy the distribution. Refer to the <i>iPlanet UDS System Management Guide</i> for more information.
envdist	Environment definitions are placed here when they are exported from the environment repository. Refer to the <i>iPlanet UDS System Management Guide</i> for more information.
external	Used as a place to put external libraries. This directory is empty at installation.
install	This directory contains installed iPlanet UDS software, as described in Table 4-8.
log	System and application log files are written here.
repos	Development repositories are created and stored here. This is the most critical directory to back up.
sysdata	This data contains information important to the iPlanet UDS runtime system and iPlanet UDS system management applications.

Table 4-7 Contents of the FORTE_ROOT directory (*Continued*)

Directory	Content
tmp	This directory is used as a temporary holding directory when making an application or library distribution that contains compiled components.
userapp	Application partitions and libraries are installed here by iPlanet UDS during the deployment process. Only application partitions that run on a particular node are installed in the userapp directory of that node.
userlib	When building an application, this directory is created to hold compiled libraries for the application. This directory does not exist when you first install Forte.
workmsg	This directory is used for working copies of message files for international language support. This directory is empty at installation.

Install Directory under FORTE_ROOT

The install directory under FORTE_ROOT contains programs, libraries, and other files used to run an iPlanet UDS system, including:

- executable files
- iPlanet UDS dynamically linked libraries
- seed repositories
- example programs (if installed)
- scripts
- diagnostic tools

Table 4-8 describes the contents of the FORTE_ROOT\install directory:

Table 4-8 FORTE_ROOT/install Directory Contents

Directory	Content
bin	iPlanet UDS system executables.
diag	Diagnostic tools used by iPlanet UDS technical support.
examples	Sample projects and examples provided by iPlanet UDS.
inc	(Development only) Header and template files used for C++ code generation and 3GL integration.
lib	C and C++ shared libraries used by iPlanet UDS system executables.

Table 4-8 FORTE_ROOT/install Directory Contents (*Continued*)

Directory	Content
nls	Internationalization files.
reposcpy	iPlanet UDS development system seed repository used by the system when creating new repositories and the iPlanet UDS system repository.
scripts	iPlanet UDS scripts, some of which the installer uses in installing iPlanet UDS on your node, and others which you can use or adapt to automate iPlanet UDS tasks, such as starting and stopping iPlanet UDS and iPlanet UDS components.

iPlanet UDS Registry Keys

If you install iPlanet UDS with Administrator privileges, the iPlanet UDS setup program defines a set of keys in the HKEY_LOCAL_MACHINE hive of the Windows registry as iPlanet UDS environment variables. If instead you install using User privileges, the setup program adds these registry changes to your HKEY_CURRENT_USER hive.

iPlanet UDS uses these keys to configure itself for such things as connecting your node to the services of an iPlanet UDS environment, and governing internal operations strictly local to your node. Each key is defined as a text string.

The following table lists some of the environment variables created by the iPlanet UDS installer for Windows installations.

Table 4-9 iPlanet UDS Environment Variables (Windows 98)

iPlanet UDS Key	Definition	Default Value
FORTE_LOGGER_SETUP	<p>A string defining how iPlanet UDS keeps logs of your use of iPlanet UDS.</p> <p>You can use the iPlanet UDS logging facility to track many kinds of iPlanet UDS processes, to isolate problems in iPlanet UDS itself, and in iPlanet UDS applications that you develop.</p> <p>When you start iPlanet UDS, the runtime system consults this key to determine what logging processes to implement.</p> <p>For more information on how to use iPlanet UDS log files and the iPlanet UDS logging facilities, see <i>iPlanet UDS System Management Guide</i>.</p>	%stdout(err:sh:*)
FORTE_NS_ADDRESS	<p>The iPlanet UDS name service address for your node. The address of the name service for the iPlanet UDS environment to which you are connecting your node. The name service is an iPlanet UDS process running on the iPlanet UDS environment's central server node, governing iPlanet UDS communication among nodes in the environment.</p> <p>The address itself consists of two parts, separated by a colon, as in <i>myserver:5000</i>, the default value. The first part of the address is the network name of the central server node, and the second part is a number between 1025 and 9000, inclusive.</p>	<i>myserver:5000</i>
FORTE_REPOSNAME	<p>The name of a central development repository for the environment.</p>	CentralRepository
FORTE_ROOT	<p>The FORTE_ROOT directory contains your iPlanet UDS installation: the executables and data files that compose the iPlanet UDS system.</p> <p>For more information about the contents of the FORTE_ROOT directory structure, see "FORTE_ROOT Directory Structure" on page 112.</p>	c:\forte
<p>PATH</p> <p><i>Environment variable, but not a registry key.</i></p>	<p>Updated to include the path to your iPlanet UDS executables located in subdirectories of the FORTE_ROOT directory.</p>	<p>The path to the file in your FORTE_ROOT directory: FORTE_ROOT\install\bin</p>

iPlanet UDS Program Group and Shortcuts

The setup program creates a Windows program group for your iPlanet UDS installation. The program group contains Windows shortcuts you can use to start and administer iPlanet UDS. Each shortcut corresponds to an iPlanet UDS application—either an executable in the %FORTE_ROOT%\install\bin directory, or an iPlanet UDS image repository in the %FORTE_ROOT%\userapp directory.

Figure 4-1 iPlanet UDS Program Group (Windows 98)

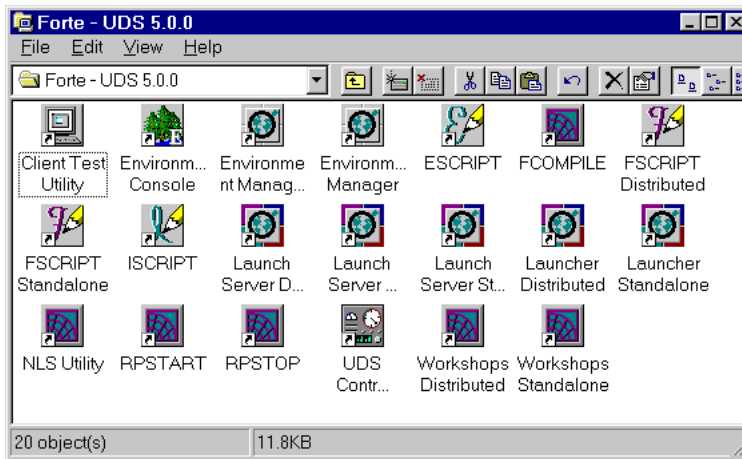

The iPlanet UDS shortcuts from the program group are also available from the Windows Start menu, under Programs > Forte - iPlanet UDS.

Workshops Distributed Shortcut

The Workshops Distributed Shortcut, pictured below opens the iPlanet UDS development workshops.



Figure 4-2 below shows the properties of the iPlanet UDS Distributed shortcut. The shortcut tab illustrates the command path and command to start the FTCMD.EXE executable, which starts the iPlanet UDS Launch Server. For information on how the Launch Server works to run iPlanet UDS applications, and on how you can configure the Launch Server to run iPlanet UDS applications that you develop, refer to the *iPlanet UDS System Management Guide*.

Figure 4-2 iPlanet UDS Distributed Shortcut (Windows NT)

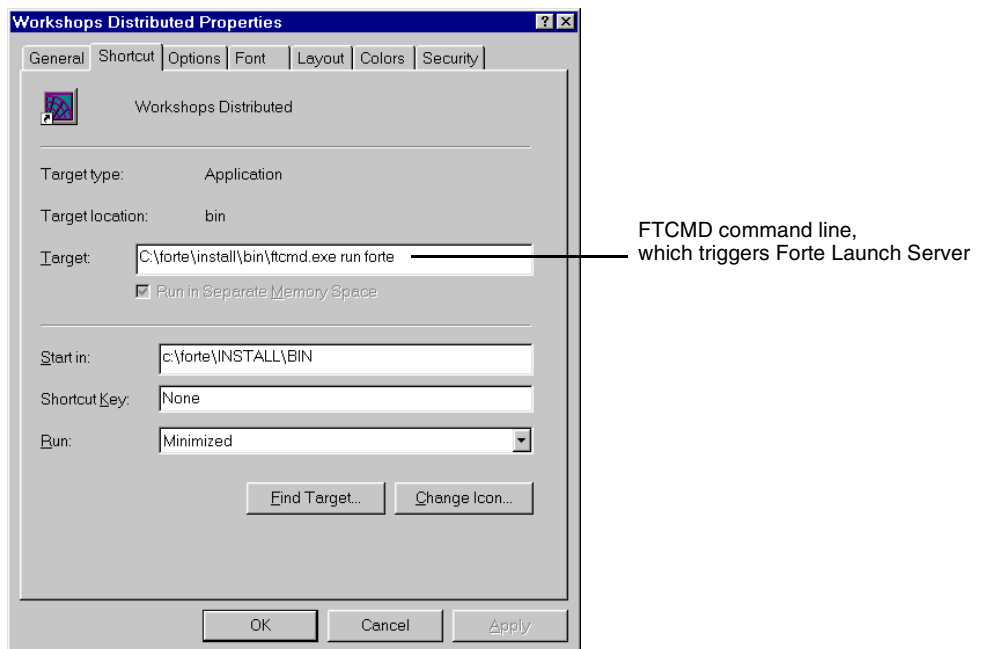

The following table defines the targets for the shortcuts in the iPlanet UDS program group. Each target is located within the %FORTE_ROOT%\install\bin directory.

Table 4-10 Windows Shortcuts for iPlanet UDS

Shortcut	Target (FORTE_ROOT\install\bin...)
Client Test Utility	FTCMD.EXE run ClientTester
Environment Console	FTCMD.EXE run EnvironmentConsole
ESCRIPT	FTEXEC.EXE -fcons -fi bt:FORTE_ROOT\USERAPP\ESCRIPT\CL0\ESCRIPT -fnw
F_COMPILE	FTEXEC.EXE -fcons -fs -fi bt:FORTE_ROOT\USERAPP\FTCOMPIL\CL0\F_COMPILE
FSCRIPT Distributed	FTEXEC.EXE -fcons -fi bt:FORTE_ROOT\USERAPP\FSCRIPT\c17\FSCRIPT -fw FirstWorkspace -fnict
FSCRIPT Standalone	FTEXEC.EXE -fs -fcons -fi bt:FORTE_ROOT\USERAPP\FSCRIPT\c17\FSCRIPT -fw FirstWorkspace -fnict
ISCRIPT	ISCRIPT.EXE
Launch Server Distributed	FTEXEC.EXE -fss -fi bt:FORTE_ROOT\USERAPP\FTLAUNCH\CL0\FTLAUNCH
Launch Server Shutdown	FTCMD.EXE shutdown server
Launch Server Standalone	FTEXEC.EXE -fs -fss -fi bt:FORTE_ROOT\USERAPP\FTLAUNCH\CL0\FTLAUNCH
Launcher Distributed	FTCMD.EXE run launcher
Launcher Standalone	FTCMD.EXE -fs run launcher
NLS Utility	FTEXEC.EXE -fs -fi bt:FORTE_ROOT\USERAPP\NLSUTIL\CL0\NLSUTIL
Workshops Distributed	FTCMD.EXE run forte
Workshops Standalone	FTEXEC.EXE -fs -fss -fi bt:FORTE_ROOT:\FORTE\USERAPP\FORTE\CL0\FORTE
UDS Control Panel	FTEXEC.EXE -fs -fss -fi bt:FORTE_ROOT:\FORTE\USERAPP\ENVIRONM\CL0\FCONTROL

NOTE Most shortcuts invoke the FTCMD or FTEXEC executables (iPlanet UDS application launching processes), passing command line arguments to them. For more information on building iPlanet UDS command lines for iPlanet UDS utilities, refer to the *iPlanet UDS System Management Guide*. For a detailed description of the iPlanet UDS application launching system, including instructions on how to use it, refer to the *iPlanet UDS Programming Guide*.

After Installing iPlanet UDS

Installing iPlanet UDS on an OpenVMS Node

This chapter describes how to install iPlanet UDS software and iPlanet UDS–Runtime Only software on OpenVMS systems running on Alpha hardware. This chapter also discusses configuring an OpenVMS node once you complete installation.

iPlanet UDS software is installed from the *iPlanet UDS Platform CD*. iPlanet UDS–Runtime Only software is installed from the *iPlanet UDS–Runtime Only CD*. For information on iPlanet UDS and iPlanet UDS–Runtime Only software, and on the iPlanet UDS CDs, refer to “[Installation Media](#)” on page 33.

Before beginning your installation, refer to the platform matrix at <http://www.forte.com/support/platforms.html> for the requirements for this release.

This chapter contains the following sections:

- “[Preparing for an iPlanet UDS Installation](#)” on page 122
- “[Installation Procedures](#)” on page 132
- “[After Installing iPlanet UDS](#)” on page 141
- “[Configuration Notes](#)” on page 151

Preparing for an iPlanet UDS Installation

Before beginning an iPlanet UDS installation, you should read **Chapter 1 on page 25**. **Chapter 1** provides background information on iPlanet UDS that is helpful to planning and installing iPlanet UDS and iPlanet UDS–Runtime Only software. You should also be familiar with information in the *iPlanet UDS System Management Guide* that describes how to set up and maintain an iPlanet UDS system.

Platform Matrix

iPlanet UDS has critical dependencies on operating systems, windowing systems, networking systems, runtime libraries, and database management systems. Before installing iPlanet UDS system software, consult the platform matrix (at <http://www.forte.com/support/platforms.html>) to make sure the target platform meets the requirements for this release.

Your system must meet the minimal requirements for the following components:

Component	Comments
Operating system	The version of the OpenVMS operating system supported for this release.
Windowing system	The type and version of the windowing system.
Networking system	Nodes with distributed installations must be able to ping server nodes.
C++ compiler	Required if you intend to integrate 3GL programs with iPlanet UDS applications or create compiled partitions and libraries.
Database systems	Required if you plan to access databases through iPlanet UDS. The database environment variable for supported databases must refer to a valid database installation before you install iPlanet UDS. Additionally, access to the database must be defined according to the database vendor's instructions.

Disk Space Requirements

An iPlanet UDS installation requires disk space in two separate areas, which may or may not be on the same disk device.

First, VMSINSTAL restores the installation savesets into a *working directory*. By default, this directory is on the system disk. However, you can specify an alternate device and directory for VMSINSTAL to use as a working directory by specifying the AWD option with VMSINSTAL.

Second, the installation procedure creates an *iPlanet UDS directory tree* on a target device you specify during installation, and installs most iPlanet UDS files into this tree.

The following table lists the approximate disk space required for installing iPlanet UDS and iPlanet UDS–Runtime Only software. Both the working directory and iPlanet UDS directory tree areas require this disk space. The actual disk space may vary, depending on the installation options you choose and the version of iPlanet UDS you are installing.

iPlanet UDS Configuration	Blocks During Installation
Full iPlanet UDS installation	309,000
Full iPlanet UDS Runtime Environment installation	188,000

► To check the available disk space on your disks, enter the following commands

```
$ SHOW DEVICES SYS$SYSTEM
$ SHOW DEVICES target_device
```

NOTE If possible, you should avoid installing iPlanet UDS on the system disk or any heavily used disk.

Modifying System Parameters

The installation procedure creates the following file, which by default installs the iPlanet UDS shared libraries as known images:

```
SYS$STARTUP:FORTE_STARTUP_version.COM
```

NOTE Even if you are in a single user environment, iPlanet UDS uses multiple processes.

You may need to adjust several system parameters to support iPlanet UDS processes. You may also need to adjust the parameters for global pages and global sections, as well as the settings for VIRTUALPAGECNT and WSMAX. The following table shows the minimum settings you should give to these parameters to ensure that iPlanet UDS runs properly:

Platform	Global Pages	Global Sections	VIRTUALPAGECNT	WSMAX
Alpha/OpenVMS	50,000	50	500,000 with Motif 270,000 without Motif	60,000

If the total number of global pages and sections required by iPlanet UDS is greater than that available, to install the desired images it may be necessary to increase the GBLPAGES and GBLSECTIONS SYSGEN parameters.

To find out how many global pages and sections are currently available for iPlanet UDS, enter the following commands:

```
$ WRITE SYS$OUTPUT F$GETSYI ("FREE_GBLPAGES")
$ WRITE SYS$OUTPUT F$GETSYI ("FREE_GBLSECTS")
```

In addition, the VIRTUALPAGECNT and WSMAX parameters act as a ceiling on the process PGFLQUO and WORKING SET quotas, respectively, and may also need to be adjusted. The VIRTUALPAGECNT parameter must be set to at least 150,000.

Also, make sure that your page file has at least 100K free blocks.

Checking Operating System and Software Versions

The iPlanet UDS development environment has critical dependencies on operating systems and software, as discussed in “[Platform Matrix](#)” on page 122. This section describes how to verify that your system meets these requirements.

OpenVMS System

The supported OpenVMS architecture and version are listed in the platform matrix at <http://www.forte.com/support/platforms.html>. To check your OpenVMS architecture, enter the following command:

```
$ WRITE SYS$OUTPUT F$GETSYI("ARCH_NAME")
```

To check your OpenVMS version, enter the following command:

```
$ WRITE SYS$OUTPUT F$GETSYI("VERSION")
```

Motif Runtime Libraries

You must have the supported version of the Motif runtime libraries, as listed in the platform matrix at <http://www.forte.com/support/platforms.html>. Several iPlanet UDS executable images are linked with the Motif runtime libraries. To verify that these runtime libraries are present on your system, enter the following command to search for the Motif runtime libraries:

```
$ DIRECTORY SYS$SHARE:DECW$XLIBSHR
```

To determine the version numbers of all DEC window images and libraries used, enter the following command:

```
$ @SYS$UPDATE:DECW$VERSIONS ALL
```

Network Support

iPlanet UDS supports both DECnet and TCP/IP communication protocols, as discussed in the section “[Platform Matrix](#)” on page 122.

DECnet To verify that DECnet is installed, enter the following command:

```
$ MCR NCP SHOW EXECUTOR Characteristics
```

The maximum links value should be at least 64. If it is not, enter the following commands (you need 8 links for each iPlanet UDS server process, or partition, you run on your OpenVMS server):

```
$ MCR NCP DEFINE EXECUTOR MAXIMUM LINKS 64
$ MCR NCP SET EXECUTOR MAXIMUM LINKS 64
```

TCP/IP For an iPlanet UDS TCP/IP stack, you can use either Compaq TCP/IP Service for OpenVMS (formerly called UCX) or Multinet.

UCX To verify that Compaq TCP/IP Service for Open VMS is installed, enter the following command:

```
$ UCX SHOW COMMUNICATION
```

If you are using Compaq TCP/IP Services for OpenVMS, it is recommended that you do not use TCP/IP communications unless you have at least version 4.0 installed. To check the version of Compaq TCP/IP Service for OpenVMS that you are running, enter the following command:

```
$ UCX SHOW VERSION
```

The version displayed should correspond to that listed in the platform matrix at <http://www.forte.com/support/platforms.html>.

Multinet Alternatively, to verify that Multinet is present on the system, enter the following command:

```
$ write sys$output f$search(f$strnlrm("MULTINET_NETWORK_IMAGE"))
```

If the file MULTINET_NETWORK_IMAGE is found, then you determine if Multinet is installed, and the version number, by entering the following command:

```
$ MULTINET SHOW /VERSION
```

The version displayed should correspond to that listed in the platform matrix at <http://www.forte.com/support/platforms.html>.

Compaq C and C++ Compiler and Runtime Libraries

iPlanet UDS software requires a Compaq C++ compiler and runtime libraries as discussed in the section [“Platform Matrix” on page 122](#). Your database vendor may also require specific versions of the Compaq C compiler and runtime libraries. To verify the version numbers of the compilers on your system, issue the following commands:

Code Example 5-1 Verifying the version number of the Compaq C++ compiler

```
$ CXX /VERSION NL:
```

Code Example 5-2 Verifying the version number of the Compaq C compiler

```
$ CC /VERSION NL:
```

To verify the runtime libraries, look for their respective disk images using the following commands:

Code Example 5-3 Verifying the runtime libraries for Compaq C++

```
$ DIRECTORY SYS$SHARE:CXXL$011_SHR
```

Code Example 5-4 Verifying the runtime libraries for Compaq C

```
$ DIRECTORY SYS$SHARE:DECC$SHR
```

Required Target Directory Structure

If you intend to provide DOS clients access to your iPlanet UDS installation, the directory structure should conform to an 8.3 naming structure. For directories, simply use names of eight or fewer characters.

Types of Installations

“Setting up an iPlanet UDS Environment” on page 28 discusses the types of nodes in an iPlanet UDS environment. During installation, you select the type of node you are installing and provide information during the installation process.

The following tables list the types of nodes in an iPlanet UDS environment, and the information you need to supply the installation program. “iPlanet UDS Environment” on page 130 provides descriptions of the information listed in these tables.

For complete information about setting up an iPlanet UDS environment, refer to the *iPlanet UDS System Management Guide*.

NOTE When installing iPlanet UDS on a node that supports a repository server, you should set a minimum value of 200,000 for the paging file quota on the FORTE server account.

Table 5-1 Nodes in an iPlanet UDS Environment (OpenVMS)

Node Type	Information Provided During Installation
Central Server	Installation path (Node manager address) Communication protocol (DECnet or TCP/IP) iPlanet UDS Name Service address Environment name Central repository name Example applications Database pathnames

Table 5-1 Nodes in an iPlanet UDS Environment (OpenVMS) (*Continued*)

Node Type	Information Provided During Installation
Server	Installation path (Node manager address) Communication protocol (DECnet and/or TCP/IP) Central server node's iPlanet UDS Name Service address Distributed repository name Example applications Database pathnames
Client Only	Installation path (Node manager address) Central server node's iPlanet UDS Name Service address Distributed repository name Example applications

Table 5-2 Nodes in an iPlanet UDS-Runtime Only Environment (OpenVMS)

Node Type	Information Provided During Installation
iPlanet UDS Runtime Client	Installation path (Node manager address) iPlanet UDS Name Service address

iPlanet UDS Environment

The following table provides details on the information you need to provide during the installation process for iPlanet UDS or the iPlanet UDS–Runtime Only. For information on the types of nodes you can install, refer to [“Types of Installations” on page 128](#).

Table 5-3 Information Required to Install iPlanet UDS (OpenVMS)

Information/Nodes	Description	Default Value
Installation path <i>all nodes</i>	Location of the iPlanet UDS directory structure. This location becomes the value of the FORTE_ROOT environment variable.	SYSSYSDEVICE:[00000]
DECnet communication: iPlanet UDS Name Service Address <i>central server</i>	If you choose DECnet as one of the node’s protocols, you must provide the DECnet name service ID (DECnet object name). The installer uses the central server node name plus this ID to set the value of the FORTE_NS_ADDRESS environment variable. The name service ID is a unique, case-sensitive, alphanumeric DECnet object name less than or equal to 8 characters in length; for example, forte_ns.	FORTE_NS
TCP/IP communication: iPlanet UDS Name Service Address <i>central server</i>	If you choose TCP/IP as one of the node’s protocols, you must provide the TCP/IP name service ID (port socket number). Use a value between 1025 and 9000, inclusive. The installer uses the central server node name plus this ID to set the value of the FORTE_NS_ADDRESS environment variable.	5000
Environment name <i>central server</i>	A name used in managing the environment. If you plan to connect environments, each environment name should be unique to simplify specification in search paths.	CentralEnv

Table 5-3 Information Required to Install iPlanet UDS (OpenVMS) *(Continued)*

Information/Nodes	Description	Default Value
Central repository name <i>central server server client only</i>	The name of the central development repository a node uses in its iPlanet UDS environment for collaborative application development.	CentralRepository
Example applications <i>central server server client only</i>	Several iPlanet UDS example programs that illustrate how to use TOOL and the iPlanet UDS classes. Examples are installed in the FORTE_ROOT:[INSTALL] directory and consist of .PEX (iPlanet UDS project export) files and other related data files. For more information on the example programs, refer to the manual, <i>A Guide to the iPlanet UDS Workshops</i> .	<i>install examples</i>
Local Oracle database <i>central server server runtime client</i>	The name and/or installation path for an Oracle database. Typically, you verify ORA_ROOT and supply the Oracle SID and the name of your Oracle database.	

The installer also prompts you for the following information:

Requested Information	Descriptions
SYS\$TIMEZONE_DIFFERENTIAL	<p>iPlanet UDS provides support for internationalization through logical names:</p> <ul style="list-style-type: none"> • FORTE_TIMEZONE • FORTE_TIMEZONE_MIN • FORTE_TIMEZONE_DST <p>During installation, you can modify the SYS\$TIMEZONE_DIFFERENTIAL. Consult your system administrator before changing the SYS\$TIMEZONE_DIFFERENTIAL</p>

Requested Information	Descriptions
iPlanet UDS server account	You can specify that the installer create this account, with a username of "FORTE." This account contains the recommended process quotas for running iPlanet UDS software.
Installation verification	You can specify that the installation verification procedure runs after installation.

Installation Procedures

This section describes the installation procedures to install iPlanet UDS and iPlanet UDS–Runtime Only software using the VMSINSTAL utility. The installation files used by VMSINSTAL consist of a set of savesets that are in the `CD_ROM_device_name:[AXP_VMS]` directory of the distribution CD.

For information on the differences between the iPlanet UDS and iPlanet UDS–Runtime Only, refer to [“About iPlanet UDS” on page 25](#).

Before you begin the installation procedure, you must first mount the distribution CD, as described in the following installation procedures. For additional information about the distribution media, refer to [“Installation Media” on page 33](#).

During installation, the VMSINSTAL program:

- requests environment information from you
- copies the FORTE_ROOT directory structure to your target node
- sets iPlanet UDS logical names on your node
- (optionally) runs iPlanet UDS servers as detached processes

Installing iPlanet UDS

The following steps describe how to use the VMSINSTAL utility to install the iPlanet UDS on an OpenVMS node. If you are installing iPlanet UDS Runtime Environment software, refer to [“Installing iPlanet UDS–Runtime Only” on page 137](#).

During installation, the install program offers you the following options:

Option	Description
Install Central Server Node	A central server node supports iPlanet UDS server partitions and hosts the iPlanet UDS system management processes—the Environment Manager and Repository Server—for an iPlanet UDS environment.
Install Server Node	A server node supports iPlanet UDS server partitions, but is not a central server node.
Install Client-Only Node	A client-only node cannot run any iPlanet UDS server partitions, but is used to develop or run iPlanet UDS applications.
Install Files Only	This option copies only the iPlanet UDS directory structure and source files to the target node, leaving the node setup for later.

For more information on setting up an iPlanet UDS environment, refer [“Setting up an iPlanet UDS Environment” on page 28](#). For a description of the information you must supply during installation, refer to [“Types of Installations” on page 128](#).

During the installation process, to accept any default values, press the Enter or Return key.

► To install iPlanet UDS software on an OpenVMS node

1. Mount the source directory for the installation.

If you are installing from the *iPlanet UDS Platform CD*, log in to a privileged account and mount the CD-ROM drive.

The following examples illustrate the mount commands:

```
MOUNT/MEDIA=CDROM /UNDEFINED_FAT=(FIXED:NONE:32256) -
_ $ CD_ROM_device_name: -
_ $FORTEDEV CD
```

Alternatively, you can run the following DCL procedure, which assists with the mount command for the CD-ROM.

```

$! Forte_CD.com:
$! Mount an iPlanet UDS software distribution CD-ROM on an
$! OpenVMS node without specifying the volume name.
$! usage:
$! @Forte_CD device_name
$! example:
$! @FORTE_CD DKA600:
$!
$ devnam = f$getdvi(p1,"DEVNAM")
$ mount/noassist/override=identification 'devnam'
$ volume = f$getdvi(devnam,"VOLNAM")
$ dismount 'devnam'
$ mount/system/media=cdrom/undefined_fat=(FIXED:NONE:32256) -
' devnam' 'volume' cd

```

2. Start VMSINSTAL, using "FORTD" as the saveset name. For example:

```

$ @SYS$UPDATE:VMSINSTAL FORTD CD_ROM_device_name:[AXP_VMS]

```

By default, VMSINSTAL restores the savesets to a temporary working directory on the system disk. If there is not enough free space on the system disk, this operation fails.

You can specify a VMSINSTAL alternate working disk by adding the following option to the VMSINSTAL command above:

```

OPTIONS AWD=disk:[dir]

```

3. Respond to VMSINSTAL prompts.

VMSINSTAL displays active non-system processes and prompts you to continue or abort the installation. It also prompts you to confirm the backup of your system disk.

CAUTION If any non-system processes are active, it is advisable to check with your system administrator before proceeding.

4. If applicable, confirm the OpenVMS version and shareable images.

The installation program performs a pre-installation check of the OpenVMS version and the versions on all iPlanet UDS-required system shareable images. If the versions are compatible, the installation continues. If the versions are not compatible, the VMSINSTAL displays the current OpenVMS version, and prompts you whether to continue or abort the installation.

5. Enter the device name of the target node for the iPlanet UDS software.

If iPlanet UDS has been previously installed (that is, if FORTE_ROOT is defined in your environment), you are asked whether you want to install in the same location.

If iPlanet UDS has not been previously installed, the installation program suggests the location SYS\$SYSDEVICE:[000000]. However, you typically install iPlanet UDS on a disk other than SYS\$SYSDEVICE.

The VMSINSTAL program uses the location of the directory you specify to set the value of the rooted logical name FORTE_ROOT.

CAUTION Make sure that FORTE_ROOT points to the name of the physical device, *not* to a logical device name.

The VMSINSTAL program then displays the following options:

```

iPlanet UDS Installation Menu
-----
 1 - Install & Setup for Central Server Node
 2 - Install & Setup for Server Node
 3 - Install & Setup for Client Node Only
 4 - Install Only
 q - Exit Installation Program
* Enter your choice [4]:

```

6. Select an installation option.

Refer to *“Types of Installations”* on page 128 for information on these installation options.

7. The installation program prompts you for node-specific information, depending on the installation option you selected in the previous step.

Refer to *“iPlanet UDS Environment”* on page 130 for a description of the information you must provide to the installation program.

8. Confirm your iPlanet UDS installation options.
9. After you confirm your iPlanet UDS installation options, the installation program prompts you for information about your environment.

Requested Information	Descriptions
Is your SYS\$TIMEZONE_DIFFERENTIAL correct?	If you answer yes, the installation proceeds. If you answer no, the installer walks you through a series of questions to set your system timezone environment. Consult your system administrator before changing the SYS\$TIMEZONE_DIFFERENTIAL
Create an iPlanet UDS server account?	This account, with a username of “FORTE,” contains the recommended process quotas for running iPlanet UDS system software.
Run installation verification procedure?	If you answer yes, the installation verification procedure runs after installation.

After you answer these questions, the installation program checks that the disk is mounted and that it has enough free space for the installation. If either of these checks fail, the installation aborts.

The installation program checks for sufficient global sections and pages. If there are not enough, the installation aborts.

If the previous checks succeed, the installation program copies the installation files, installs the example applications (if this option was selected), and starts the appropriate system management processes.

For information about the command procedures the installation program creates for defining iPlanet UDS symbols and logicals, as well as starting system management processes, see *“After Installing iPlanet UDS”* on page 141.

Installing iPlanet UDS–Runtime Only

Use the VMSINSTAL utility with the *iPlanet UDS–Runtime Only CD* to install the iPlanet UDS–Runtime Only software. If you are installing iPlanet UDS software, refer to [“Installing iPlanet UDS” on page 132](#).

During installation, the install program offers you only the following option:

Option	Description
Install Client–Only Node	A client-only node cannot run any iPlanet UDS server partitions, but is used to develop or run iPlanet UDS applications.

For information on setting up an iPlanet UDS environment, refer [“Setting up an iPlanet UDS Environment” on page 28](#). For a description of the information you must supply during installation, refer to [“Types of Installations” on page 128](#).

During the installation process, to accept any default values, simply hit the Enter or Return key.

► To install iPlanet UDS–Runtime Only software on an OpenVMS node

1. Mount the source directory for the installation.

If you are installing from the *iPlanet UDS–Runtime Only CD*, log in to a privileged account and mount the CD–ROM drive.

The following examples illustrate the mount commands:

```
MOUNT/MEDIA=CDROM /UNDEFINED_FAT=(FIXED:NONE:32256) -
_ $ CD_ROM_device_name: -
_ $RTV CD
```

Alternatively, you can run the following DCL procedure, which assists with the mount command for the CD-ROM.

```

$! Forte_CD.com:
$! Mount an iPlanet UDS software distribution CD-ROM on an
$! OpenVMS node without specifying the volume name.
$! usage:
$! @Forte_CD device_name
$! example:
$! @FORTE_CD DKA600:
$!
$ devnam = f$getdvi(p1,"DEVNAM")
$ mount/noassist/override=identification 'devnam'
$ volume = f$getdvi(devnam,"VOLNAM")
$ dismount 'devnam'
$ mount/system/media=cdrom/undefined_fat=(FIXED:NONE:32256) -
' devnam' 'volume' cd

```

2. Start VMSINSTAL, using "FTRTV" as the saveset name. For example:

```

$ @SYS$UPDATE:VMSINSTAL FTRTV CD_ROM_device_name:[AXP_VMS]

```

By default, VMSINSTAL restores the savesets to a temporary working directory on the system disk. If there is not enough free space on the system disk, this operation fails.

You can specify a VMSINSTAL alternate working disk by adding the following option to the VMSINSTAL command above:

```

OPTIONS AWD=disk:[dir]

```

3. Respond to VMSINSTAL prompts.

VMSINSTAL displays active non-system processes and prompts you to continue or abort the installation. It also prompts you to confirm the backup of your system disk.

CAUTION If any non-system processes are active, it is advisable to check with your system administrator before proceeding.

4. If applicable, confirm the OpenVMS version and shareable images.

The installation program performs a pre-installation check of the OpenVMS version and the versions on all iPlanet UDS-required system shareable images. If the versions are compatible, the installation continues. If the versions are not compatible, the VMSINSTAL displays the current OpenVMS version, and prompts you whether to continue or abort the installation.

5. Enter the device name of the target node for the iPlanet UDS software.

If iPlanet UDS has been previously installed (that is, if FORTE_ROOT is defined in your environment), you are asked whether you want to install in the same location.

If iPlanet UDS has not been previously installed, the installation program suggests the location SYS\$SYSDEVICE:[000000]. However, you typically install iPlanet UDS on a disk other than SYS\$SYSDEVICE.

The VMSINSTAL program uses the location of the directory you specify to set the value of the rooted logical name FORTE_ROOT.

CAUTION Make sure that FORTE_ROOT points to the name of the physical device, *not* to a logical device name.

The VMSINSTAL program then displays the following options:

```

iPlanet UDS Runtime Installation
-----
  Install & Setup for the Forte Runtime System
  Q - Exit Installation Program
  Press <Enter> to Continue or Q to Exit
```

6. Select an installation option.

Refer to [“Types of Installations” on page 128](#) for information on these installation options.

7. The installation program prompts you for node-specific information, depending on the installation option you selected in the previous step.

Refer to [“iPlanet UDS Environment” on page 130](#) for a description of the information you must provide to the installation program.

8. Confirm your iPlanet UDS installation options.
9. After you confirm your iPlanet UDS installation options, the installation program prompts you for information about your environment.

Requested Information	Descriptions
Is your SYS\$TIMEZONE_DIFFERENTIAL correct?	If you answer yes, the installation proceeds. If you answer no, the installer walks you through a series of questions to set your system timezone environment. Consult your system administrator before changing the SYS\$TIMEZONE_DIFFERENTIAL
Create an iPlanet UDS server account?	This account, with a username of “FORTE,” contains the recommended process quotas for running iPlanet UDS system software.
Run installation verification procedure?	If you answer yes, the installation verification procedure runs after installation.

After you answer these questions, the installation program checks that the disk is mounted and that it has enough free space for the installation. If either of these checks fail, the installation aborts.

Otherwise, the installation program copies and uncompresses the installation files, installs the example applications (if this option was selected), and starts the appropriate system management processes.

The installation program checks for sufficient global sections and pages. If there are not enough, the installation aborts.

For information about the command procedures the installation program creates for defining iPlanet UDS symbols and logicals, as well as starting system management processes, see [“After Installing iPlanet UDS” on page 141](#).

After Installing iPlanet UDS

This section discusses your iPlanet UDS environment on OpenVMS, and OpenVMS procedures you perform after the installation is complete.

FORTE_ROOT Directory Structure

The installation program creates the rooted logical name, `FORTE_ROOT`, in your `SYS$STARTUP:FORTE_STARTUP_version.COM` file. `FORTE_ROOT` points to the directory tree of your iPlanet UDS distribution.

CAUTION Do not change the structure of the `FORTE_ROOT` directory. The structure must remain intact for iPlanet UDS to function properly—iPlanet UDS relies on the path links within the structure to locate and use iPlanet UDS components.

The installation program installs the `FORTE_ROOT` structure at the location you choose. You can later move the location of `FORTE_ROOT`, but you must keep the structure intact. If you move the location of `FORTE_ROOT`, then you must change the iPlanet UDS logicals and path specifications in your `SYS$STARTUP:FORTE_STARTUP_version.COM` and `SYS$LIBRARY:FORTE_LOGIN_version.COM` files.

The following table describes the contents of the subdirectories in the `FORTE_ROOT` directory structure:

Table 5-4 Contents of the `FORTE_ROOT` Directory Structure (OpenVMS)

Directory	Description
<code>FORTE_ROOT:[APPDIST]</code>	<p>Location for all application and library distribution files created when you make a distribution. Also, user-developed distributions can be placed here from a CD-ROM or other media so they can be deployed in an iPlanet UDS environment.</p> <p>The iPlanet UDS installer also places iPlanet UDS system application distributions in this directory to be deployed when you install iPlanet UDS system software. Refer to the <i>iPlanet UDS System Management Guide</i> for more information.</p>

Table 5-4 Contents of the FORTE_ROOT Directory Structure (OpenVMS) (*Continued*)

Directory	Description
FORTE_ROOT:[ENVDIST]	Exported environment definitions. This directory is empty at installation. For more information about creating and using environment definitions see the <i>iPlanet UDS System Management Guide</i> .
FORTE_ROOT:[EXTERNAL]	This directory is empty at installation.
FORTE_ROOT:[INSTALL]	A large number of files and subdirectories, all devoted to executing the iPlanet UDS development system. For a detailed description of the contents of the [INSTALL] subdirectory, see the table below.
FORTE_ROOT:[LOG]	iPlanet UDS log files. For information about configuring the iPlanet UDS logging facilities, see the <i>iPlanet UDS System Management Guide</i> .
FORTE_ROOT:[REPOS]	iPlanet UDS user repositories, including the example programs repository, created on demand at installation.
FORTE_ROOT:[SYSDATA]	Contains the environment repository and other information important to the iPlanet UDS runtime system and iPlanet UDS system management.
FORTE_ROOT:[TMP]	Files that the iPlanet UDS system creates for its own use while iPlanet UDS is running.
FORTE_ROOT:[USERAPP]	Location for all applications (iPlanet UDS partitions) and libraries installed on this node. Only application partitions that run on a particular node are installed in the userapp directory of that node. Partitions are installed by iPlanet UDS system management services during the application deployment process, and can include both user-developed application partitions and iPlanet UDS system application partitions. Refer to the <i>iPlanet UDS System Management Guide</i> for more information.
FORTE_ROOT:[WORKMSG]	Compiled message catalogs that you create for the purpose of internationalizing your iPlanet UDS applications. For more information about creating compiled message catalogs, and internationalizing your iPlanet UDS applications, see the <i>iPlanet UDS Programming Guide</i> . This directory is empty at installation.

FORTE_ROOT:[INSTALL] Directory

The FORTE_ROOT:[INSTALL] directory contains much of what the iPlanet UDS system uses to run itself, including:

- executables
- iPlanet UDS shareable images
- seed repositories
- example programs (if you have installed them)
- scripts
- diagnostic tools

The following table describes the contents of the FORTE_ROOT:[INSTALL] directory:

Table 5-5 FORTE_ROOT:[INSTALL] Directory Contents (OpenVMS)

Directory	Description
[.BIN]	iPlanet UDS system executables. For more information about using and configuring the programs in this directory, see the <i>iPlanet UDS System Management Guide</i> .
[.DIAG]	Diagnostic tools used by iPlanet UDS technical support.
[.EXAMPLES]	Sample projects and examples provided by iPlanet UDS.
[.INC]	(Development only) Header and template files used for C++ code generation and 3GL integration.
[.LIB]	3GL libraries for inclusion in iPlanet UDS applications that you build. The iPlanet UDS shareable images (files with FORTE%%SHR \over ver.EXE names) are the compiled code extensions to the iPlanet UDS system.
[.NLS]	Internationalization files.
[.REPOSCPY]	iPlanet UDS development system seed repository used by the system when creating new repositories and the iPlanet UDS system repository.
[.SCRIPTS]	iPlanet UDS scripts, some of which the VMSINSTAL program uses in installing iPlanet UDS on your node, and others which you can use or adapt to automate iPlanet UDS tasks, such as starting and stopping iPlanet UDS and iPlanet UDS components.

Editing the System Files

After you have installed iPlanet UDS on OpenVMS, you should edit the system startup and system login files, modify system parameter settings, set user and server process quotas, and test iPlanet UDS, as described below.

We recommend that you edit the system startup file to provide for automatic startup of iPlanet UDS when your system is rebooted, and edit the system login file to define iPlanet UDS symbols. This editing must be done after networking has been started (DECnet and/or TCP/IP).

Editing the OpenVMS System Startup File

Typically, the system startup file is:

```
SYS$STARTUP:SYSTARTUP_VMS.COM
```

Add the following command to the system startup:

```
$ SUBMIT SYS$STARTUP:FORTE_STARTUP_version/USER=FORTE
```

This startup script contains a command to execute the server startup as a batch job. Make sure your default batch queue (typically, SYS\$BATCH) is started before the startup script is submitted.

As an alternative, you can add the following command to the system startup file to start iPlanet UDS as username SYSTEM:

```
$ @SYS$STARTUP:FORTE_STARTUP_version
```

However, make sure that you have set the file ownership:

```
$ SET FILE/OWNER=SYSTEM DEVICE:[FORTE...]*.*
```

Whichever command you choose, make sure it appears after the DECnet and/or TCP/IP startup. Because of the time it takes to start iPlanet UDS server processes, this portion of the startup can take a while. Submitting to a batch job may be preferable for faster bootstrapping

Editing the System Login File

The system-wide login file is:

```
SYS$MANAGER:SYLOGIN.COM
```

It is recommended that you add the following command to the system login file, at a point where it is executed by all types of processes:

```
$ INSTALL := $INSTALL/COMMAND
$ @SYS$LIBRARY:FORTE_LOGIN_version
```

As an alternative, only those users who are using iPlanet UDS can put these commands into their personal SYS\$LOGIN:LOGIN.COM files.

To make further login customizations, you can add the file FORTE_ROOT:[INSTALL.SCRIPTS]SITE_LOGIN.COM, which is automatically executed by the SYS\$LIBRARY:FORTE_LOGIN_version.COM procedure.

Shutting Down iPlanet UDS Server Processes

To perform an orderly shutdown of iPlanet UDS server processes, enter the following command from a suitably privileged account (usually either FORTE or SYSTEM):

```
$ @SYS$STARTUP:FORTE_SHUTDOWN_version.COM
```

NOTE If you run this command on a server or client node, it also shuts down the central server node. As you add or alter components of your iPlanet UDS installation this command procedure may need to be modified.

iPlanet UDS User Account Requirements

To work with iPlanet UDS, user accounts on your OpenVMS system must have certain privileges and quotas.

User account When you start iPlanet UDS system applications (the iPlanet UDS workshops, the Environment Console, Fscript, or Escript) or start iPlanet UDS server partitions manually, you should use iPlanet UDS user account privileges and quotas.

System account When you start iPlanet UDS system management services, such as the node manager or the environment manager, you should use system account privileges and quotas. All iPlanet UDS partitions started by these services will then start under the system account.

To run iPlanet UDS executables, you must have the following user privileges:

- TMPMBX
- NETMBX

To modify the quotas for iPlanet UDS user accounts, you can use the following commands:

```
$ MCR AUTHORIZE
UAF> MODIFY USER/quota=xxx
UAF> SHOW USER
UAF> EXIT
```

If you have not added this line to the SYLOGIN.COM file, then have users set logicals and symbols by adding the following to their SYS\$LOGIN:LOGIN.COM file:

```
$ @SYS$LIBRARY:FORTE_LOGIN_version
```

iPlanet UDS Server Account Requirements

To start iPlanet UDS system management processes, such as the environment manager, name service, and node manager, the following privileges are required:

- DETACH
- TMPMBX
- NETMBX

Server account quotas Quotas for iPlanet UDS server detached processes have defaults that can be overridden by logical names. The values of these logical names are translated only when the node manager creates its first process. If you modify any of the logical names and the node manager has already created a server process, you must stop and restart the node manager.

User account quotas The following table provides the general guidelines for process quotas.

Process	Quota
ASTLM	1500
BIOLM	500
BYTLM	300000
DIOLM	500
ENQLM	2000
FILLM	300
PGFLQUO	100000 VAX 170000 AXP

Process	Quota
PRCLM	8
SHRFILLM	0
TQELM	100
WSDEF	1024
WSQUO	5000
WSEXTENT	40000 VAX 60000 AXP

The following table shows the logical names (the corresponding quota is specified in the name) and the default value used if the logical name is not defined:

Logical Name	Default Value
FORTE_DETACHED_FILLM	300
FORTE_DETACHED_BIOLM	500
FORTE_DETACHED_DIOLM	500
FORTE_DETACHED_ASTLM	1500
FORTE_DETACHED_TQELM	100
FORTE_DETACHED_ENQLM	2,000
FORTE_DETACHED_BYTLM	300,000
FORTE_DETACHED_JTQUOTA	0
FORTE_DETACHED_WSDEF	1,024
FORTE_DETACHED_WSQUO	5,000
FORTE_DETACHED_WSEXTENT (VAX)	40,000
FORTE_DETACHED_WSEXTENT (Alpha)	60,000
FORTE_DETACHED_PGFLQUO (VAX)	100,000
FORTE_DETACHED_PGFLQUO (Alpha)	170,000

Testing Your Installation

You can test your iPlanet UDS installation by running iPlanet UDS in distributed mode.

► **To run iPlanet UDS in distributed mode**

1. Use the following DCL command to login:

```
$ @SYS$LIBRARY:FORTE_LOGIN
```

2. Start the iPlanet UDS workshops with either:

- o the DCL command, `forte`:

```
$ forte
```

- o or, use the DCL command verb, `vforte` (see `$HELP VFORTE`):

```
$ vforte forte
```

If you installed the iPlanet UDS example applications, you can run them from the Repository Workshop.

► **To run the iPlanet UDS examples from the demo30 repository**

1. Make a private copy of the demo30 repository.

The VMSINSTAL program sets the demo30 repository permissions so that users cannot write to the repository. Therefore, you should copy the two repository files, DEMO30.BTD and DEMO30.BDX, so you can write to the new repository. To do this, use the following command:

```
$ copy FORTE_ROOT:[REPOS]DEMO30.*
FORTE_ROOT:[REPOS]MYDEMO30.*
```

2. Set your display, if necessary:

```
$ SET DISPLAY/CREATE/NODE = yournode [/TRANSPORT=TCPIP]
```

3. Start iPlanet UDS in standalone mode to run against your new demo30 repository by running either the DCL foreign commands or DCL command verb as follows:

- o the DCL foreign command

```
$ forte -fs -fr bt:FORTE_ROOT:[REPOS]DEMO30
```

- o the DCL command verb

```
$ vforte forte -
/standalone/repository=bt:FORTE_ROOT:[REPOS]DEMO30
```

Configuration Notes

Logical Names

The installation program creates two iPlanet UDS logical name tables that track iPlanet UDS logicals on OpenVMS. These tables not only prevent iPlanet UDS logicals from cluttering the system logical table, but also make it possible to run several name services—and different versions of iPlanet UDS—on the same server. This means that multiple environments can be configured, started, and maintained on a single OpenVMS central server.

The two iPlanet UDS logical name tables are as follows:

Table 5-6 iPlanet UDS Logical Name Tables (OpenVMS)

Logical Name Table	Description
Global logical name table (FORTE_ GBLTABLE_ <i>version</i>)	<p>A system-wide logical name table. All iPlanet UDS system-wide logicals, such as FORTE_ROOT, are stored here. This logical name table is created by SYS\$STARTUP:FORTE_STARTUP_ <i>version</i>.COM.</p> <p>This logical name table is created with a parent table directory of LNM\$SYSTEM_DIRECTORY</p>
Process logical name table (FORTE_ PRCTABLE)	<p>A process-level logical name table. All logicals defined by iPlanet UDS SETENV method are in this logical name table. The logicals in this table are passed to any child processes it creates. This logical name table is created by</p> <p>SYS\$LIBRARY:FORTE_LOGIN_ <i>version</i>.COM (which calls FORTE_ROOT:[INSTALL.SCRIPTS]FORTE_LOGIN.COM).</p> <p>This logical name table is created with a parent table directory of LNM\$PROCESS_DIRECTORY.</p>

Search Priority

The following table shows the search path hierarchy iPlanet UDS uses in interpreting logical names. iPlanet UDS respects user-defined names in the usual search order (defined by the LNM\$DCL_LOGICAL). The search order, with the LNM\$FILE_DEV logical set by the FORTE_ROOT:[INSTALL.SCRIPTS]FORTE_LOGIN.COM file, is listed in the following table:

Search Priority	Logical Name Table
1	LNM \$PROCESS_TABLE
2	LNM \$JOB
3	FORTE_PRCTABLE
4	LNM\$GROUP
5	FORTE_GBL_ <i>version</i>
6	LNM \$SYSTEM
7	DECW\$LOGICAL_NAMES

Network Protocols

OpenVMS platforms can support both DECnet and TCP/IP protocols at the same time. The definition of the logical name FORTE_LOCATIONS depends on your answers to installation questions and on your FORTE_NS_ADDRESS.

VMSINSTAL asks you whether the iPlanet UDS name service accepts DECnet and/or TCP/IP connections. Depending on your answers, the definition for the logical name FORTE_LOCATIONS specifies that the name server accept DECnet and/or TCP/IP connections. In addition, the FORTE_NS_ADDRESS logical name is modified automatically to support either DECnet or TCP/IP or both.

Setting FORTE_LOCATIONS

The FORTE_LOCATIONS setting indicates which protocols iPlanet UDS uses to accept inbound connections (that is, to respond to calls from remote processes).

In general, a node uses the same protocols for both receiving and initiating communication, however this is not always the case. There may be situations when a node wants to advertise only a subset of the protocols it is actually capable of receiving. For example, it may only advertise a DECnet location but initiate outbound TCP/IP connections.

If you want to customize your setup, you have to modify the definition of FORTE_LOCATIONS from those set by the installation program. The following commands illustrate this. In these examples, *version* is the ID of the iPlanet UDS release, for example, "30n0":

Code Example 5-5 DECnet-only support

```
$ DEFINE/TABLE=FORTE_GBLTABLE_<i>version</i> FORTE_LOCATIONS -
  "qqDEFAULT_LOC: :DECnet "
```

Code Example 5-6 TCP/IP-only support

```
$ DEFINE/TABLE=FORTE_GBLTABLE_<i>version</i> FORTE_LOCATIONS
  "qqDEFAULT_LOC"
```

Code Example 5-7 DECnet and TCP/IP support

```
$ DEFINE/TABLE=FORTE_GBLTABLE_<i>version</i> FORTE_LOCATIONS -
  "qqDEFAULT_LOC: :DECnet ;qqDEFAULT_LOC"
```

Setting FORTE_NS_ADDRESS

The syntax you use to set FORTE_NS_ADDRESS varies depending upon the network services your setup uses.

The FORTE_NS_ADDRESS syntax for the three possible configurations is listed below. On the line beneath the syntax is an example for a node named Venus (using the installer's default value of "FORTE_NS" for the FORTE_NS_NAME and 30n0 for the iPlanet UDS release number):

Code Example 5-8 Syntax for setting FORTE_NS_ADDRESS on DECnet only

```
$ DEFINE/TABLE=FORTE_GBTABLE_<version> FORTE_NS_NAME -
"DECNET_NODENAME:FORTE_NS_NAME::DECnet"

$ DEFINE/TABLE=FORTE_GBTABLE_30n0 FORTE_NS_NAME -
VENUS:FORTE_NS::DECnet
```

Code Example 5-9 Syntax for setting FORTE_NS_ADDRESS on TCP/IP only

```
$ DEFINE/TABLE=FORTE_GBTABLE_<version> FORTE_NS_NAME -
"tcpip_nodename:tcpip_port_number"

$ DEFINE/TABLE=FORTE_GBTABLE_30n0 FORTE_NS_NAME -
VENUS:1016
```

Code Example 5-10 Syntax for setting FORTE_NS_ADDRESS on DECnet and TCP/IP

```
$ DEFINE/TABLE=FORTE_GBTABLE_<version> FORTE_NS_NAME -
"DECNET_NODENAME:NS_NAME::DECnet;tcpip_nodename:port_number"

$ DEFINE/TABLE=FORTE_GBTABLE_30n0 FORTE_NS_NAME -
VENUS:FORTE_NS::DECnet;venus:1016
```

Installing iPlanet UDS and the iPlanet UDS Transaction Adapter on OS/390

This chapter describes how to install iPlanet UDS software on an OS/390 node and the iPlanet UDS Transaction Adapter for OS/390.

The iPlanet UDS software for installation on the OS/390 platform comes on IBM 3490 tape media. The document *Restoring the iPlanet UDS for OS/390 Product Tape* provides instructions for the MVS user who unloads the tape in preparation for installation. *Restoring the iPlanet UDS for OS/390 Product Tape* is provided as hard copy with your iPlanet UDS media distribution. For completeness, this information is repeated in this chapter.

This chapter contains the following sections:

- “Preparing for an iPlanet UDS Installation” on page 155
- “Installation Procedure” on page 161
- “After Installing iPlanet UDS” on page 165
- “Testing iPlanet UDS” on page 172
- “Installing the Transaction Adapter for OS/390” on page 174

Preparing for an iPlanet UDS Installation

Before beginning an iPlanet UDS installation, you should read [Chapter 1 on page 25](#). [Chapter 1](#) provides background information on iPlanet UDS that is helpful to planning and installing iPlanet UDS and iPlanet UDS–Runtime Only software. You should also be familiar with information in the *iPlanet UDS System Management Guide* that describes how to set up and maintain an iPlanet UDS system.

Platform Matrix

iPlanet UDS has critical dependencies on operating systems, windowing systems, networking systems, runtime libraries, and database management systems. Before installing iPlanet UDS system software, consult the platform matrix (at <http://www.forte.com/support/platforms.html>) to make sure the target platform meets the requirements for this release.

Your system must meet the minimal requirements for the following components:

Component	Comments
Operating system	The version of the OS/390 operating systems supported for this release.
Networking system	Nodes with distributed installations must be able to ping server nodes.
C++ compiler	Required if you intend to integrate 3GL programs with iPlanet UDS applications or create compiled partitions and libraries.
Database systems	Required if you plan to access databases through iPlanet UDS. The database environment variable for supported databases must refer to a valid database installation before you install iPlanet UDS. Additionally, the environment variable providing access must be defined according to the database vendor's instructions. For more information on database access, refer to <i>"Understanding the fortedef Script"</i> on page 168.
External interface	Required if you plan distributed access using third party tools.

Who Should Install the Software?

iPlanet UDS system software for the OS/390 platform comes on IBM 3490 tape media, with standard labels, in IEBGENER format. The MVS user who unloads the tape and runs the iPlanet UDS installation script must:

- be able to run MVS batch jobs
- be able to login to the UNIX Services environment (using OMVS, telnet, or rlogin)
- have read/write access to the iPlanet UDS unload directory and the iPlanet UDS installation directory in the Hierarchical File System (HFS)

- know how to edit and submit JCL from TSO
- know how to execute basic commands in the OS/390 UNIX Services environment

Requirements for Installation

The iPlanet UDS system software and runtime system software for OS/390 requires IBM OS/390 Release 2.7 or later. You must have an MVS installation at or above the maintenance level required.

To unload and install iPlanet UDS system software, you must first create a temporary directory in the OS/390 UNIX HFS that can be deleted after the installation is complete.

Disk space The unloading directory requires at least 80 MB of disk space for the HFS path where you unload the software. The installation directory requires at least 240 MB of disk space for the iPlanet UDS software.

Installation Options

“Setting up an iPlanet UDS Environment” on page 28 discusses the types of nodes in an iPlanet UDS environment. During installation, you select the type of node you are installing and provide information during the installation process.

NOTE iPlanet UDS for OS/390 can serve only as a deployment environment, *not* as an application development environment. You can install iPlanet UDS to set up your node as one of two kinds of server nodes or you can install just the iPlanet UDS files.

During installation, you select the type of node you are installing and provide information during the installation process. The following tables list the types of nodes you can install on an OS/390 node and the information you need to supply the installation program. “iPlanet UDS Environment” on page 159 provides descriptions of the information listed in this table.

For complete information about setting up an iPlanet UDS environment, refer to the *iPlanet UDS System Management Guide*.

iPlanet UDS on OS/390 Node

Node	Node Property and Other Information
Central Server	Installation path Port ID for iPlanet UDS Name Service DB2 CLI Initialization File name Environment name Distributed repository name Example applications
Server	Installation path iPlanet UDS Name Service address DB2 CLI Initialization File name Distributed repository name Example applications
iPlanet UDS files	This option copies only the iPlanet UDS directory structure and source files to the target node, leaving the node setup for later.

iPlanet UDS Environment

The following table provides details on the information you need to provide during the installation process for the iPlanet UDS on OS/390. For information on the types of nodes you can install, refer to [“Installation Options” on page 157](#).

Table 6-1 Information Required to Install iPlanet UDS (OS/390)

Information/Nodes	Description	Default Value
Installation path <i>all nodes</i>	Location of the iPlanet UDS directory structure. This location becomes the value of the FORTE_ROOT environment variable.	/forte
Port ID for iPlanet UDS Name Service <i>central server</i>	<p>A unique port ID on the central server node specifying the Name Service Address. The port ID must be a number between 1025 and 65536 inclusive.</p> <p>The Name Service Address identifies the node in the context of its iPlanet UDS environment, and must therefore be a unique identity within the environment at any time. The address consists of the network name of the central server node and the specified port ID, separated by a colon (for example, <i>myserver:5000</i>). This is the value specified by the node's FORTE_NS_ADDRESS environment variable, which the installation program sets using the value you provide.</p> <p>When installing the central server node, specify only the port ID.</p>	5000
iPlanet UDS Name Service Address <i>server</i>	<p>The address a server node uses to connect to the name service for the iPlanet UDS environment. The name service is an iPlanet UDS process running on the iPlanet UDS environment's central server node, governing iPlanet UDS communication among nodes in the environment.</p> <p>The address itself consists of the network name of the central server node and the specified port ID, separated by a colon (for example, <i>myserver:5000</i>). The port ID is specified during the installation of the central server node.</p> <p>The installation program uses the value specified for the iPlanet UDS Name Service Address to set the FORTE_NS_ADDRESS environment variable.</p> <p>You should be able to ping the server by name if the name is part of the name service address, or by the IP address if the IP address is part of the name service address. Use the TSO ping command or the UNIX Services oping command if available, to ensure TCP/IP connectivity to the Name Service node.</p>	none

Table 6-1 Information Required to Install iPlanet UDS (OS/390) (Continued)

Information/Nodes	Description	Default Value
DB2 CLI Initialization File name <i>central server</i> <i>server</i>	<p>The name of the MVS dataset that contains initialization information required by the DB2 Call Level Interface (CLI). You need to set the iPlanet UDS environment variable DSNAOINI to a value for this dataset name. For more information, refer to “Understanding the fortedef Script” on page 168 and also to the manual <i>Using iPlanet UDS for OS/390</i>.</p> <p>The dataset name can be in either upper or lowercase and, if a PDS is being specified, the entire dataset name with the member enclosed in parentheses must be enclosed in quotes to prevent USS from treating the parentheses as special characters. See Chapter 4 of IBM manual SC26-8959, <i>DB2 for OS/390 Version 5 Call Level Interface Guide and Reference</i> for more information about creating this file.</p>	
Environment name <i>central server</i>	A name used in managing the environment. If you plan to connect environments, each environment name should be unique to simplify specification in search paths.	CentralEnv
Distributed repository name <i>central server</i> <i>server</i>	The name of the central development repository a node uses in its iPlanet UDS environment for collaborative application development.	CentralRepository
Example applications <i>central server</i> <i>server</i>	Several iPlanet UDS example programs that illustrate how to use TOOL and the iPlanet UDS classes. Examples are installed in the \$FORTE_ROOT/install directory and consist of .pex (iPlanet UDS project export) files and other related data files. For more information on the example programs, refer to the manual, <i>A Guide to the iPlanet UDS Workshops</i> .	<install examples>

Installation Procedure

The iPlanet UDS installation software for the OS/390 platform comes on IBM 3490 tape media, with standard labels, in IEBGENER format. The tape contains a UNIX tape archive (tar) file that contains the iPlanet UDS Software.

To install iPlanet UDS, you must unload the tar file into a temporary directory in your UNIX Hierarchical File System (HFS), run the UNIX tar command to expand the file, and then run the UNIX installation shell script INSTALL.SH to build your iPlanet UDS distribution in a permanent location.

Depending on the installation options you choose, the installation script:

- requests certain environment information from you
- creates the iPlanet UDS installation directory, and copies the iPlanet UDS directory structure and source files to the installation directory
- sets the iPlanet UDS installation's environment variables
- configures the appropriate iPlanet UDS system management services for the installation

The following steps describe how to install iPlanet UDS on an OS/390 node.

► To install iPlanet UDS on an OS/390 node with UNIX Services

1. Log in to the UNIX Services environment using the user ID that will be used to unload the iPlanet UDS product tape and install the iPlanet UDS software.

The user ID must have read/write privileges for files in the FORTE_ROOT directory where iPlanet UDS will be installed.

You can log in using either the TSO OMVS command, or by using an rlogin or telnet client on another system.

2. Create a temporary directory for unloading the tape.

For example, to create /tmp/forte for unloading the tape, issue the UNIX command:

```
mkdir /tmp/forte
```

NOTE Make sure that each file system has enough space available, as described in [“Requirements for Installation” on page 157](#).

3. Log on to TSO.
4. Create and submit an IEBGENER batch job to unload the tar file from the 3490 tape cartridge into the temporary unloading directory created in [Step 2](#) above.

Below is an example JCL file you can use to place the FORTE.TAR file into the temporary HFS directory /tmp/forte:

```
//FRTEUNLD JOB (0000)
//*
//UNLOAD EXEC PGM=IEBGENER
//SYSIN DD DUMMY
//SYSPRINT DD SYSOUT=*
//SYSUT1 DD DSN=FORTE.TAR,DISP=OLD,
// UNIT=3490,
// VOL=SER=<volser_from_external_label>,
// LABEL=(1,SL),
// BLKSIZE=27920,LRECL=80,RECFM=FB
//SYSUT2 DD PATH='/tmp/forte/forte.tar',
// PATHOPTS=(OWRONLY,OCREAT,OEXCL),
// PATHMODE=(SIRWXU,SIRGRP,SIROTH)
```

5. Log in to the UNIX Services environment again using the same user ID you used to unload the iPlanet UDS product tape.

6. Expand the tar file that you unloaded in [Step 4 on page 162](#).

If you unloaded the iPlanet UDS tar file into /tmp/forte/forte.tar, use the following two UNIX commands to complete this step:

```
cd /tmp/forte
tar xovf forte.tar
```

7. Navigate to the ALL_UNIX directory of the installation files and execute the installation script:

```
./INSTALL.SH
```

8. The installer prompts you for a target directory for your iPlanet UDS installation.

```
Specify the iPlanet UDS installation path (default is /forte):
```

If the target directory you specify does not exist, the installer creates it for you.

9. When installing iPlanet UDS system software, the installer provides you with the following options:

```
iPlanet UDS Installation Menu
-----

1 - Install & Setup for Central Server Node
2 - Install & Setup for Server Node
3 - Install Files Only
q - Exit Installation Program

Select Option [1, 2, 3, q (default is 1)]:
```

Refer to the previous section, **“Installation Options”** on page 157, for a description of the installation options.

10. As you proceed, the installer prompts you for additional information.

Refer to **“iPlanet UDS Environment”** on page 159 for a description of the information you need to provide for each option.

11. Confirm your installation options.

For example:

```
CONFIRMATION:
-----
Installation Option: iPlanet UDS Install & Setup for Central
Server Node.
. . .
Do you wish to continue the installation with these options?
(y/n, default is y)
```

If you want to change a selection, specify **“n”** to abort the installation, and then start the installation script again.

After you confirm your choices, the installation proceeds to completion.

NOTE The installation aborts if the target disk is not mounted or if there is not enough free disk space for the installation to complete.

12. After installation is complete, remove the temporary directory where you unloaded the tape.

For example, if you unloaded the tape into `/tmp/forte`, you can remove the directory with the command:

```
rm -rf /tmp/forte
```

After Installing iPlanet UDS

Your iPlanet UDS installation on OS/390 contains the following components:

- FORTE_ROOT directory structure

For information on this directory structure, refer to

[“FORTE_ROOT Directory Structure” on page 166.](#)

- fortedef script

The fortedef script is a shell script that defines the iPlanet UDS configuration for your node in a series of environment variables. The installation script initially sets these values according to the information you provide.

For more information on the fortedef script, refer to [“Understanding the fortedef Script” on page 168.](#)

- forteboot script

The forteboot script is a shell script that you use to start iPlanet UDS. The script contains commands to start iPlanet UDS components according to a configuration you define. Initially, forteboot uses the default configuration defined by the fortedef script.

For more information on the forteboot script, refer to [“Understanding the forteboot Script” on page 170.](#)

FORTE_ROOT Directory Structure

FORTE_ROOT is the directory you define as the target directory for your iPlanet UDS installation. The installation script sets the location of your FORTE_ROOT directory as the value of the FORTE_ROOT environment variable.

CAUTION Do not change the structure of the FORTE_ROOT directory. The directory structure must remain intact for iPlanet UDS to function properly—iPlanet UDS relies on the path links within the structure to locate and use iPlanet UDS components.

The installation script installs the FORTE_ROOT structure at the location you choose. You can later move the location of FORTE_ROOT, but you must keep the structure intact. If you move the location of FORTE_ROOT, then you should change any iPlanet UDS environment variable that defines the location of files and directories in the structure.

Table 6-2 describes the contents of the directory structure defined by FORTE_ROOT:

Table 6-2 Contents of the FORTE_ROOT directory

Directory	Content
appdist	Application and library distributions are created here when a developer makes a distribution, or placed here when you copy a distribution from a tape or other media in order to deploy the distribution. Refer to the <i>iPlanet UDS System Management Guide</i> for more information.
envdist	Environment definitions are placed here when they are exported from the environment repository. Refer to the <i>iPlanet UDS System Management Guide</i> for more information.
external	Used as a place to put external libraries. This directory is empty at installation.
install	This directory contains installed iPlanet UDS software, as described in Table 6-3 .
log	System and application log files are written here.
repos	Development repositories are created and stored here. This is the most critical directory to back up.
sysdata	This data contains information important to the iPlanet UDS runtime system and iPlanet UDS system management applications.

Table 6-2 Contents of the FORTE_ROOT directory (*Continued*)

Directory	Content
tmp	This directory is used as a temporary holding directory when making an application or library distribution that contains compiled components.
userapp	Application partitions and libraries are installed here by iPlanet UDS during the deployment process. Only application partitions that run on a particular node are installed in the userapp directory of that node.
userlib	When building an application, this directory is created to hold compiled libraries for the application. This directory does not exist when you first install Forte.
workmsg	This directory is used for working copies of message files for international language support. This directory is empty at installation.

Install Directory

The FORTE_ROOT/install directory contains much of what the iPlanet UDS system uses to run itself, including:

- executable programs
- iPlanet UDS dynamically linked libraries
- B-tree seed repositories
- example programs (if installed)
- scripts
- diagnostic tools

Table 6-3 describes the contents of the FORTE_ROOT/install directory:

Table 6-3 FORTE_ROOT/install Directory Contents

Directory	Content
bin	iPlanet UDS system executables.
diag	Diagnostic tools used by iPlanet UDS technical support.
examples	Sample projects and examples provided by iPlanet UDS.
inc	(Development only) Header and template files used for C++ code generation and 3GL integration.
lib	C and C++ shared libraries used by iPlanet UDS system executables.

Table 6-3 FORTE_ROOT/install Directory Contents (*Continued*)

Directory	Content
nls	Internationalization files.
reposcpy	iPlanet UDS development system seed repository used by the system when creating new repositories and the iPlanet UDS system repository.
scripts	iPlanet UDS scripts, some of which the INSTALL.SH program uses in installing iPlanet UDS on your node, and others which you can use or adapt to automate iPlanet UDS tasks, such as starting and stopping iPlanet UDS and iPlanet UDS components.

Understanding the fortedef Script

The fortedef shell script (located at \$FORTE_ROOT/fortedef.sh) defines the iPlanet UDS configuration for your node in a series of environment variables, according to the information you pass to it at installation time. It also defines the appropriate `s` dynamically linked library path for your platform. For more information about setting environment variables, refer to the *iPlanet UDS System Management Guide*.

Creating and Using fortedef Scripts

You can use the fortedef script as a template for creating other fortedef scripts for other iPlanet UDS configurations, or for other users. To use your own fortedef scripts, you can either source them manually before starting iPlanet UDS, or reference them in your `.login` file.

You can also include a fortedef script in your `.profile` file to automatically initialize your UNIX System Services environment for iPlanet UDS access.

iPlanet UDS Environment Variables

The following table lists the environment variables created or amended by the iPlanet UDS installer for UNIX installations.

Table 6-4 iPlanet UDS Environment Variables (OS/390)

Environment Variable	Definition	Default Value
FORTE_LOGGER_SETUP	<p>A string defining how iPlanet UDS keeps logs of your use of iPlanet UDS.</p> <p>You can use the iPlanet UDS logging facility to track many kinds of iPlanet UDS processes, and to isolate problems in iPlanet UDS itself and in iPlanet UDS applications that you develop.</p> <p>When you start iPlanet UDS, the runtime system consults this key to determine what logging processes to implement.</p> <p>For more information on how to use iPlanet UDS log files and the iPlanet UDS logging facilities, see the <i>iPlanet UDS System Management Guide</i>.</p>	%stdout(err:sh:*)
FORTE_NS_ADDRESS	<p>The iPlanet UDS name service address for your node. The address of the name service for the iPlanet UDS environment to which you are connecting your node. The name service is an iPlanet UDS process running on the iPlanet UDS environment's central server node, governing iPlanet UDS communication among nodes in the environment.</p> <p>The address itself consists of two parts, separated by a colon, as in <i>myserver:5000</i>, the default value. The first part of the address is the network name of the central server node, and the second part is a number between 1025 and 9000, inclusive.</p>	myserver:5000
FORTE_REPOSNAME	The name of central development repositories.	CentralRepository
FORTE_ROOT	<p>The FORTE_ROOT directory contains your iPlanet UDS installation: the executables and data files that compose the iPlanet UDS system.</p> <p>For more information about the contents of the FORTE_ROOT directory structure, see "FORTE_ROOT Directory Structure" on page 166.</p>	/forte

Table 6-4 iPlanet UDS Environment Variables (OS/390) (Continued)

Environment Variable	Definition	Default Value
PATH	Updated to include the path to your iPlanet UDS executables and shared libraries located in subdirectories of the FORTE_ROOT directory.	The path to the file in your FORTE_ROOT directory: FORTE_ROOT/install/bin
DSNAOINI	The name of the MVS dataset that contains initialization information required by the DB2 Call Level Interface (CLI). The value of this variable is used to set node properties as described in “ iPlanet UDS Environment ” on page 159. For more information, refer to the manual <i>Using iPlanet UDS for OS/390</i> . See also Chapter 4 of IBM manual <i>SC26-8959, DB2 for OS/390 Version 5 Call Level Interface Guide and Reference</i> for more information about the MVS dataset file.	Determined at installation.
LIBPATH	Updated to include the path to database libraries. You can modify the LIBPATH environment variable to include the library directory for databases you have added after the initial iPlanet UDS installation. The LIBPATH variable must be set on the server where the database resides before you start the iPlanet UDS Node Manager or iPlanet UDS executable. LIBPATH settings are platform specific. For more information see <i>Accessing Databases</i> .	Automatically set at installation.

Understanding the forteboot Script

The installation script creates the forteboot script that you can use to start iPlanet UDS or any of its components. The script contains commands to start iPlanet UDS server processes.

NOTE The forteboot script is not created for iPlanet UDS runtime software installations.

The forteboot script starts iPlanet UDS system management processes according to the setup options selected during installation. For example, if you selected the central server setup option, the forteboot script starts an environment manager process and repository server process.

For the OS/390, the forteboot script is available for the Bourne shell:

Bourne Shell \$FORTE_ROOT/forteboot.sh

Creating and Using forteboot Scripts

You can modify the forteboot script to add whatever shell-based logic you like, such as prompts for using different fortedef files, or different command lines for starting various iPlanet UDS applications. You can also use the forteboot script as a template to make other forteboot scripts.

You can include the forteboot script in your rc.local file to automatically bring up the iPlanet UDS node manager and repository server whenever UNIX Services starts running in your OS/390 environment.

You should place the forteboot command at the end of your startup file, after the startup of TCP/IP INETD daemon. Because of the time it takes to start iPlanet UDS server processes, this portion of the startup can take a noticeable length of time.

The following table defines the commands embedded in the forteboot.sh script:

Command	Purpose
<code>source fortedef.csh</code>	Sets variables as defined in fortedef file.
<code>\$FORTE_ROOT/install/bin/start_nodemgr -e <i>environment name</i></code>	Starts the environment manager process for the environment.
<code>\$FORTE_ROOT/install/bin/rpstart -fr bt: -n <i>repository name</i></code>	Starts the Repository Service for the environment.

You can modify the forteboot script to add whatever shell-based logic you like, such as prompts for using different fortedef files, or different command lines for starting various iPlanet UDS applications. You can also use the forteboot script as a template to make other forteboot scripts.

Testing iPlanet UDS

You can test your installation by running iPlanet UDS in distributed mode.

➤ **To run iPlanet UDS in distributed mode**

1. Start your central server node processes.

You can start the processes by sourcing your `forteboot` script, which starts your runtime environment. For more information on setting up an iPlanet UDS environment, see the *iPlanet UDS System Management Guide*.

2. Using the `forte` command, start the iPlanet UDS Repository Workshop on *another node* connected to the OS/390 iPlanet UDS environment. (iPlanet UDS for OS/390 does not support use of the iPlanet UDS Workshops.)

For example, the following command starts iPlanet UDS using the central development repository you specified during installation:

```
% forte
```

If you installed the iPlanet UDS example applications, you can run them from the Repository Workshop on a non-OS/390 node in the environment.

➤ **To run the iPlanet UDS examples from the demo30 repository**

1. On any non-OS/390 node in your environment, start iPlanet UDS in standalone mode to run against the demo30 repository using the following command:

```
% forte -fs -fr bt:$FORTE_ROOT/repos/demo30
```

For information about iPlanet UDS command syntax and command flags, see *A Guide to the iPlanet UDS Workshops*.

Customizing Sample Applications for iPlanet UDS Application Server for OS/390

You can run the sample applications shipped with iPlanet UDS if you observe the following restrictions:

- Any project making calls to the display library cannot be deployed on an OS/390 platform. You can, however, deploy it on a client node.
- The dmathtm project will not link correctly on OS/390 unless you remove the libc library reference from the dmathtm.pex file.

To fix this problem you need to edit the file dmathtm.pex and change the following line:

```
Extended = (External SharedLibs = '/usr/shlib/libc',  
ExternalObjectFiles = '%{FORTE_ROOT} /tmp/examples/dmathtm')
```

The corrected line should read as follows:

```
Extended = (ExternalObjectFiles = '%{FORTE_ROOT}  
/tmp/examples/dmathtm')
```

The TimeIt sample application does not run on OS/390.

Installing the Transaction Adapter for OS/390

This section explains how to do the following tasks:

- install the iPlanet UDS Transaction Adapter for OS/390 software from the distribution media
- load the OS/390 example applications
- install and execute the installation verification programs for CICS, IMS, and APPC/MVS

NOTE For information about known problems associated with the use of the COBOLField class, please look up Bulletin 421 at <http://www.forte.com/support/bulletins.html>.

Requirements

The IBM 3490 tape cartridge contains the following files:

File Name	Purpose
FORTE.JCL	IEBCOPY unload of a partitioned dataset that contains JCL for defining, building, and installing the OS/390 components of the example applications
FORTE.SOURCE	IEBCOPY unload of a partitioned dataset that contains source for the OS/390 components of the example applications, as well as sample system definitions required for their installation

Each of the following requirements must be met before installing the iPlanet UDS Transaction Adapter for OS/390:

- The current release of iPlanet UDS for OS/390 must be installed on the OS/390 nodes where the Transaction Adapter will be installed.
- The current release iPlanet UDS must be installed on the nodes from which the Transaction Adapter project APPC will be used in client applications.

- The supported release of OS/390 is running on the OS/390 nodes where the Transaction Adapter will be installed. Refer to the Platform Matrix at <http://www.forte.com/support/platforms.html> for the supported release of OS/390.

NOTE The filenames and label names used to load, install, and execute the iPlanet UDS Transaction Adapter for OS/390 are dependent on the current release number for iPlanet UDS. This section provides instructions for iPlanet UDS Release 5.0.1. For subsequent releases, you may have to modify the filenames and label names accordingly.

Loading the OS/390 Examples

The example APPC/MVS, CICS, and IMS applications for the OS/390 system come on the same IBM 3490 tape media as the iPlanet UDS Application Server for OS/390, as additional files in IEBCOPY unload format. The tape contains IEBCOPY unloads of two partitioned datasets, one containing JCL files and the other containing source files, as files 2 and 3 on the tape.

To install the OS/390 components of the example applications, you must load both partitioned datasets from the tape and then customize and submit the JCL to install the example applications. The JCL PDS is named FORTE.V501.JCL and the source PDS is named FORTE.V501.SOURCE. Note that if you rename the source dataset, you have to change all references to it in the JCL.

► To load the partitioned datasets from the distribution tape

1. Log on to TSO.
2. Create and submit an IEBCOPY batch job to load the partitioned datasets from the 3490 tape.

Below is an example JCL file you can use to load the partitioned datasets:

```
//FRTELOAD JOB(000)
//LOADJCL EXEC PGM=IEBCOPY, REGION=4M
//SYSPRINT DD SYSOUT=*
//INPUT DD DSN=FORTE.JCL,
// DISP=(OLD,PASS),
// UNIT=3490,
// VOL=SER=FOR501,
// LABEL=(2,SL)
//OUTPUT DD DSN=FORTE.V501.JCL,
// DISP=(NEW,CATLG),
```

```

//          UNIT=SYSDA,
//          VOL=SER=volser,
//          SPACE=(27920,(4,1,5)),
//          DCB=(RECFM=FB,LRECL=80,BLKSIZE=27920)
//SYSIN    DD *
          COPY INDD=INPUT,OUTDD=OUTPUT
//LOADSRC EXEC PGM=IEBCOPY,REGION=4M
//SYSPRINT DD SYSOUT=*
//INPUT    DD DSN=FORTE.SOURCE,
//          DISP=(OLD,KEEP),
//          UNIT=3490,
//          VOL=SER=FOR501,
//          LABEL=(3,SL)
//OUTPUT   DD DSN=FORTE.V501.SOURCE,
//          DISP=(NEW,CATLG),
//          UNIT=SYSDA,
//          VOL=SER=volser,
//          SPACE=(27920,(10,2,5)),
//          DCB=(RECFM=FB,LRECL=80,BLKSIZE=27920)
//SYSIN    DD *
          COPY INDD=INPUT,OUTDD=OUTPUT
//

```

In the above example, volser is the volume serial number of the DASD volume where you want to allocate the partitioned datasets.

Installation Verification Procedures

The installation verification procedures consist of defining APPC/MVS profiles, installing a simple application, and executing that application to verify that the Transaction Adapter can communicate with the OLTP system. For each OLTP system (APPC/MVS, CICS, and IMS) there is an OLTP application that consists of a simple transaction program that takes any input message, reverses it, and sends it back to the originator, and an iPlanet UDS application to drive the OLTP transaction program using the Transaction Adapter.

Installation Verification for APPC/MVS

The IVP for APPC/MVS consists of the FRTMEX01 REXX program and the MVSivp iPlanet UDS application. If you plan to use the Transaction Adapter to access native APPC/MVS applications that execute outside of the CICS or IMS environments, you should perform the steps described in this section to verify that the Transaction Adapter can successfully access an APPC/MVS application.

APPC/MVS System Preparation

For APPC/MVS, two system definitions are required: a side information profile and a TP profile. You build these definitions using the APPC/MVS definition utility. The name of the side information profile is referred to as the *symbolic destination name*.

- The JCL to build the side information profile is in FORTE.V501.JCL(FRTMEXSI).
- The JCL to build the TP profile is in FORTE.V501.JCL(FRTMTP01).

The JCL contains detailed comments that describe how to customize the JCL for your installation.

► **To build the side information and TP profiles**

1. Locate the required JCLs.
2. Tailor the JCL in FRTMEXSI.
3. Submit the job to define the FRTMEXSI profile to APPC/MVS.
4. Tailor the JCL in FRTMTP01 to define the FRTMEX01 TP profile to APPC/MVS.

Note that the TP profile contains the JCL that will execute the FRTMEX01 example program, and that this JCL must also be tailored before the job is submitted.

5. Submit the job to define the FRTMTP01 profile to APPC/MVS.

APPC/MVS Application

The source for the FRTMEX01 program is in FORTE.V501.SOURCE(FRTMEX01). This program is written in REXX, which is an interpretive language. Therefore, no preparation is necessary for the program.

iPlanet UDS Application

The project export of the MVSivp project is in the FORTE_ROOT/install/examples/extsys/txadapt/mvsivp.pex file. Use the workshop to import this project into your workspace, and then deploy it as a client on the machine where you wish to run the application. The project deploys into two partitions, a client partition and a server partition containing the APPCApiSO service object. Make sure that the server partition is deployed on the OS/390 node where you have installed the Transaction Adapter for OS/390.

The MVSivp project contains two classes: Echo is the class that interfaces with the APPC/MVS REXX program using the Transaction Adapter classes, and EchoWindow is the window class that provides the user interface.

The application assumes that the side information profile FRTMEXSI has been defined on your system and accesses the APPC/MVS system where you have installed the REXX application. It also assumes that the REXX application name is FRTMEX01. If either of these names has been changed, you must modify the Run method of the Echo class to specify the correct names.

Execution of the IVP

► **To execute the APPC/MVS IVP**

1. Start up the client application on your client system.
 - On Windows NT, choose Start > Programs > Forte Applications > MVSivp.
 - On Unix, enter the following command:

```
ftexec -fi bt:$FORTE_ROOT/userapp/mvsivp/cl0/mvsivp0 &
```

A GUI screen will appear, with the Symbolic Destination Name field initialized to FRTMEXSI.

If you have defined a different symbolic destination name, overtype this field with the correct name.

2. Click the Run button.

The Text Received field should show the following text:

```
Congratulations, your application is communicating with  
APPC/MVS
```

Installation Verification for CICS/ESA and CICS/TS

The IVP for CICS/ESA and CICS/TS consists of the FRTCX01 CICS program and the CICSivp iPlanet UDS application. If you plan to use the Transaction Adapter to access CICS applications, you should perform the steps described in this section to verify that the Transaction Adapter can successfully access a CICS application

APPC/MVS System Preparation

The Transaction Adapter requires an APPC/MVS side information profile in order to access a CICS system. The side information profile is built using the APPC/MVS definition utility.

- The LU name that is referenced by the side information profile must be the CICS VTAM LU name.
- The JCL to build the side information profile for CICS is in FORTE.V501.JCL(FRTCEXSI).

The JCL contains comments that describe how to customize the JCL for your installation. Tailor the JCL in FRTCEXSI and submit the job to define the FRTCEXSI profile to APPC/MVS.

CICS System Preparation

At many installations, the definition of new CICS transactions requires the involvement of the CICS system programmer or system administrator. If your site requires this, have the CICS system programmer or system administrator perform the definition of the CICS transaction.

The JCL to build the CICS system definitions for the CICS FRTCEX01 program is in FORTE.V501.JCL(CSDCEX01).

► **To define the CICS program and corresponding transaction**

- Tailor the JCL and submit the job to define the FRTCEX01 program and FR01 transaction to CICS. This job uses the CICS CSD update utility to build the definitions.
- Alternatively, you can manually enter these definitions into CICS using the CEDA transaction. After the definitions have been built, use CEDA to install the group to which the definitions were added. The JCL as shipped adds the definitions to the FORTE group.

CICS IVP Transaction

The source for the FRTCEX01 program is in FORTE.V501.SOURCE(FRTCEX01). The JCL to assemble and link this program is in FORTE.V501.JCL(FRTCEX01). Tailor the JCL and submit the job to assemble and link the program into a library accessible to CICS.

iPlanet UDS IVP Application

The project export of the CICSivp project is in the FORTE_ROOT/install/examples/extsys/txadapt/cicsivp.pex file.

1. Import this project into your workspace using the iPlanet UDS Repository Workshop.
2. Use the workshop to deploy it as a client on the machine where you wish to run the application.

The project deploys into two partitions, a client partition and a server partition containing the APPCApiSO service object.

3. Make sure that the server partition is deployed on the OS/390 node where you installed the Transaction Adapter for OS/390.

The CICSivp project contains two classes: Echo is the class that interfaces with the CICS transaction using the Transaction Adapter classes, and EchoWindow is the window class that provides the user interface.

This example assumes that the symbolic destination name, FRTCEXSI, has been defined on your system and accesses the CICS system where you have installed the CICS transaction. It also assumes that the CICS transaction name is FR01. If either of these names has been changed, you must modify the Run method of the Echo class to specify the correct names.

Execution of the IVP

The first step in the installation verification procedure for CICS is to execute the CICS IVP transaction directly from a CICS 3270 terminal to ensure that the CICS transaction program is installed correctly. The next step in the installation verification procedure is to execute the CICS IVP transaction through the Transaction Adapter using the iPlanet UDS CICSivp application.

► **To ensure that the CICS transaction program is installed correctly**

1. Log on to your CICS system.
2. Press the Clear key.
3. Type the following text and press Enter.

```
fr01 This is a test
```

The response TSET A SI SIHT 10RF should appear immediately following your original input.

4. Log off from your CICS system by pressing the Clear key, typing the following text, and pressing Enter.

```
cesf logoff
```

► **To execute the CICS IVP transaction through the Transaction Adapter using the iPlanet UDS CICSivp application**

1. Start up the client application on your client system.
 - On Windows NT, choose Start > Programs > Forte Applications > CICSivp.
2. On Unix, enter the following command:

```
ftexec -fi bt:$FORTE_ROOT/userapp/cicsivp/cl0/cicsiv0 &
```

A GUI screen appears, with the Symbolic Destination Name field initialized to FRTCEXSI.

If you have defined a different symbolic destination name, type over this field with the correct name.

3. Click the Run button.

The Text Received field should show the following text:

```
Congratulations, your application is communicating with CICS
```

Installation Verification for IMS/TM

IMS System Preparation

At most installations, the definition of new IMS transactions requires the involvement of the IMS system programmer or system administrator. If your site requires this, have the IMS system programmer or system administrator perform the definition of the IMS transaction.

With IMS, a stage 1 and stage 2 system generation must be performed to define the IVP transaction to IMS/TM. This must be completed before the transaction can be used. Sample IMS definitions for the transaction are in FORTE.V501.SOURCE(DEFIEX01). These definitions should be added to your IMS stage 1 source and then a system generation should be performed. At some installations, the IMS online change utility can be used to install the updates into the running IMS system without a restart of IMS. Your IMS system administrator should know whether or not this is allowed and should be involved in the process.

In addition to the system generation, IMS requires that a PSB and an ACB be built for a transaction.

- The source for the PSB for the transaction is in FORTE.V501.SOURCE(FRTIEP01).
- The JCL to perform the PSBGEN and the ACBGEN is in FORTE.V501.JCL(GENIEX01).

This JCL should be tailored and then submitted to build the PSB and ACB for the application. At some installations, the IMS online change utility can be used to install these into the running IMS system without a restart of IMS. Your IMS system administrator should know whether or not this is allowed and should be involved in the process.

IMS IVP Transaction

The source for the FRTIEX01 program is in FORTE.V501.SOURCE(FRTIEX01). The JCL to assemble and link this program is in FORTE.V501.JCL(FRTIEX01).

To build the IMS transaction, tailor the JCL in FRTIEX01 and submit the job to assemble and link the FRTIEX01 program.

iPlanet UDS IVP Application

The project export of the IMSivp project is in the FORTE_ROOT/install/examples/extsys/txadapt/imsivp.pex file.

1. Import this project into your workspace using the workshop.
2. Use the workshop to deploy it as a client on the machine where you wish to run the application.

The project deploys into two partitions, a client partition and a server partition containing the APPCApiSO service object.

3. Make sure that the server partition is deployed on the OS/390 node where you installed the Transaction Adapter for OS/390.

The IMSivp project contains two classes: Echo is the class that interfaces with the IMS transaction using the Transaction Adapter classes, and EchoWindow is the window class that provides the user interface.

This example assumes that the symbolic destination name, FRTIEXSI, has been defined on your system and accesses the IMS system where you have installed the IMS transaction. It also assumes that the IMS transaction name is FRTIEX01. If either of these names has been changed, you must modify the Run method of the Echo class to specify the correct names.

Execution of the IVP

The first step in the installation verification procedure for IMS/TM is to execute the IMS IVP transaction directly from an IMS 3270 terminal to ensure that the IMS transaction program is installed correctly. The next step in the installation verification procedure is to execute the IMS IVP transaction through the Transaction Adapter using the iPlanet UDS IMSivp application.

► **To ensure that the IMS transaction program is installed correctly**

1. Log on to your IMS system.
2. Type the following text and press Enter.

```
frtiex01 This is a test
```

The screen should clear and the response TSET A SI SIHT should appear on the third row of the screen.

3. Log off from your IMS system by typing the following text and pressing Enter.

```
/rcl
```

► **To execute the IMS IVP transaction through the Transaction Adapter using the iPlanet UDS IMSivp application**

1. Start up the client application on your client system.
 - On Windows NT, choose Start > Programs > Forte Applications > IMSivp.
 - On Unix, enter the following command:

```
ftexec -fi bt:$FORTE_ROOT/userapp/imsivp/c10/imsivp0 &
```

A GUI screen appears, with the Symbolic Destination Name field initialized to FRTIEXSI. If you have defined a different symbolic destination name, type over this field with the correct name.

2. Click the Run button.

The Text Received field should show the following text:

```
CONGRATULATIONS, YOUR APPLICATION IS COMMUNICATING WITH IMS
```